

AC Air Compressor



浙江鸿川动力科技有限公司

HONGCHUAN POWER TECHNOLOGY CO.,LTD



About Us

Zhejiang Hongchuan Power Technology Co.,Ltd was first established in 2010,which is a large-scale enterprise group,specializing in R&D and manufacturing various kinds of air compressors and vacuum pumps .We have 20+ engineers with more than 10 years experience ,from the structural design, appearance design and mold development all can be done by our own R&D team.

Our products mainly serve industries such as medical equipment,dental equipment,robotic arms,automation equipment,beauty equipment,packaging equipment,new energy vehicles and pond aeration systems etc .

Dedicated to strict quality control and thoughtful customer service,our experienced engineers are always available to discuss your requirements and ensure full customer satisfaction.

Our main markets include the USA,Mexico,Germany, Japan ,UK,Italy,Spain,Australia,Russia,Indonesia and South Korea etc. We welcome the OEM and ODM orders.

Whether selecting a current product from our catalog or seeking engineering assistance for your application,you can talk to our customer service center about your sourcing requirements.

Adhering to the business principle of mutual benefits,we have had a reliable reputation among our customers because of our professional services,quality products and competitive prices , looking forward to your collaboration .



**Air Compressor Solutions Backed
by 20 Years of Global Success.**

Trusted by 8,000+ Clients Worldwide.

Application



Dental Equipment



Laboratory And Medical



Ozone Generator



Beauty Machine



Oxygen Machine



Pond Aerator

AC Oil Free Air Compressor

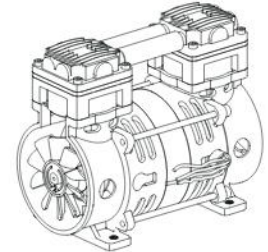
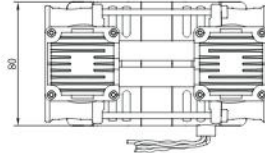
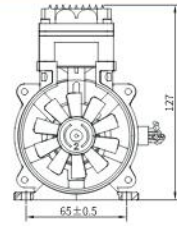
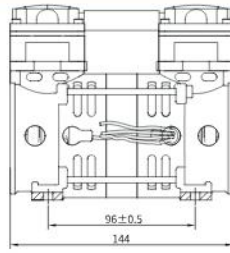

Technical Specification		
Model Number	HC80A-17/1.4	HC80B-17/1.4
Head configuration	Pressure parallel fow	Pressure parallel fow
Voltage	220V/50Hz/1	110V/60Hz/1
Power at rated pressure	≤110 W	≤90 W
Air flow rate	17L/min@140Kpa	21L/min@140Kpa
Speed at rated pressure	1400rpm	1700rpm
Dimension	144*80*127 mm	144*80*127 mm
Installation size	95*65mm	95*65mm
Net weight	2.05kg	2.05kg
Operating ambient air temperature	-5 to 40℃	-5 to 40℃
Thermal protection	145±5℃	145±5℃
Motor insulation class	F	F
Capacitor value	3.5μF	8μF

Performance Chart - Flow VS. Pressure

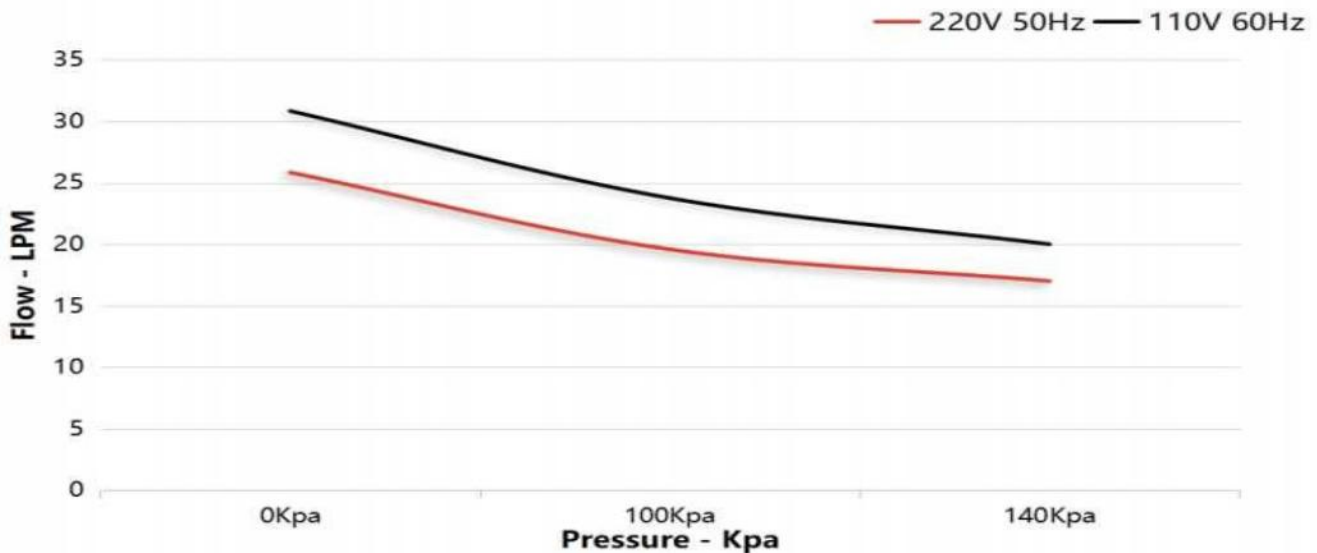

AC Oil Free Air Compressor

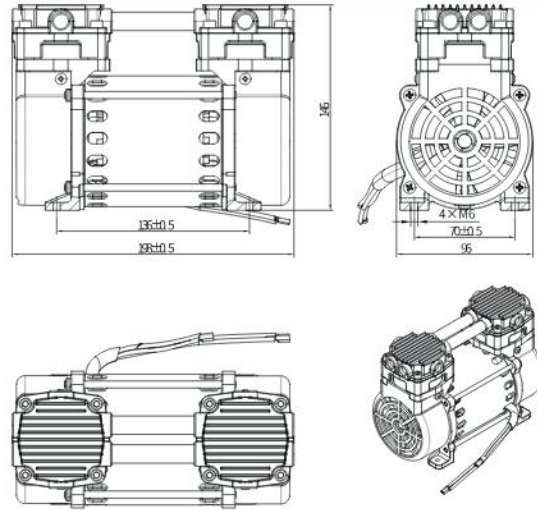

Technical Specification		
Model Number	HC100A-9/7	HC100B-10/7
Head configuration	Pressure parallel fow	Pressure parallel fow
Voltage	220V/50Hz/1	110V/60Hz/1
Power at rated pressure	≤190W	≤230W
Air flow rate at rated pressure	9L/min@700Kpa	10L/min@700Kpa
Speed at rated pressure	1400rpm	1700rpm
Dimension	198×96×146mm	198×96×146mm
Installation size	136×70mm	136×70mm
Net weight	4.3kg	4.3kg
Operating ambient air temperature	-5 to 40°C	-5 to 40°C
Thermal protection	145±5°C	145±5°C
Motor insulation class	F	F
Capacitor value	8μF	15μF

Performance Chart - Flow VS. Pressure

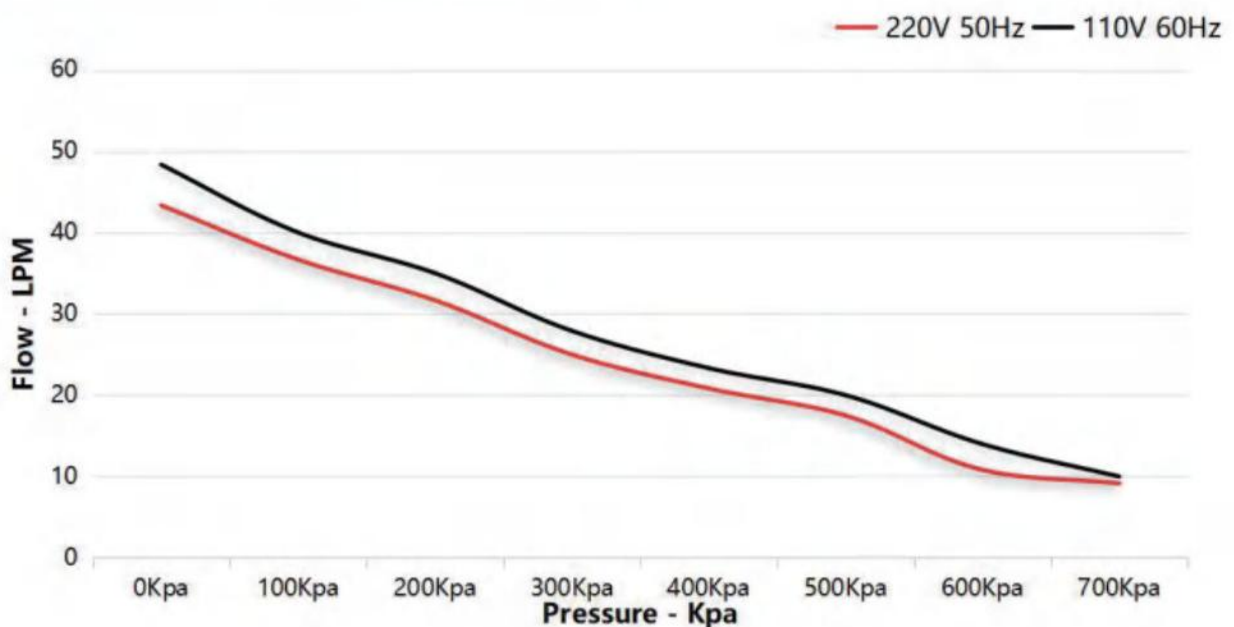

AC Oil Free Air Compressor

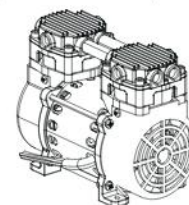
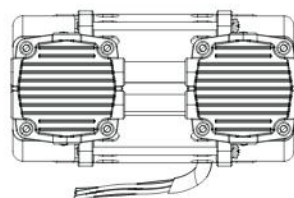
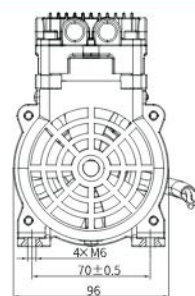
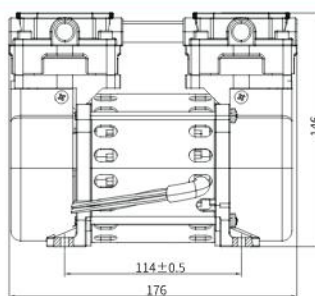

Technical Specification

	HC100A-30/2	HC100B-38/2
Model Number	HC100A-30/2	HC100B-38/2
Head Configuration	Pressure parallel flow	Pressure parallel flow
Voltage	220V/50Hz/1	110V/60Hz/1
Power at rated pressure	≤180W	≤220W
Air flow rate at rated pressure	≥30L/min@200Kpa	≥38L/min@200Kpa
Speed at rated pressure	1400 rpm	1700 rpm
Dimension	176*96*146 mm	176*96*146 mm
Installation size	114*70mm	114*70mm
Net Weight	3.4 kg	3.4 kg
Operating ambient temperature	-5 to 40°C	-5 to 40°C
Thermal protection	145±5°C	145±5°C
Motor insulation class	F	F
Capacitor value	6μF	15μF

Performance Chart - Flow VS. Pressure

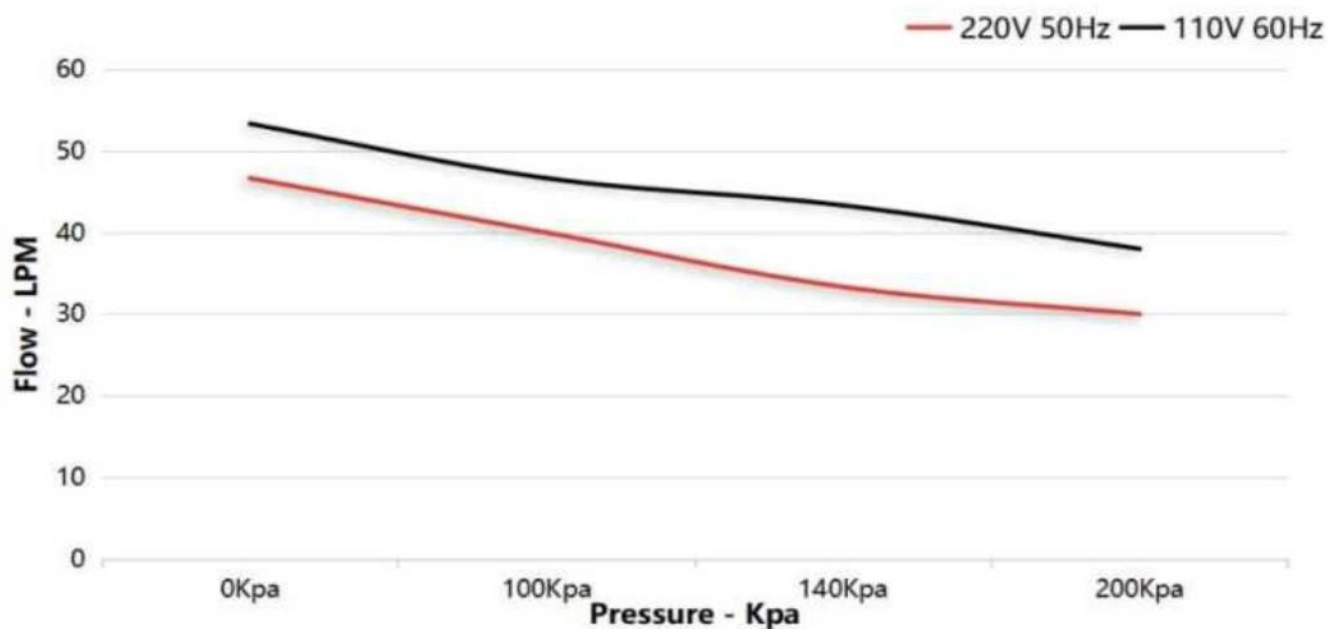

AC Oil Free Air Compressor

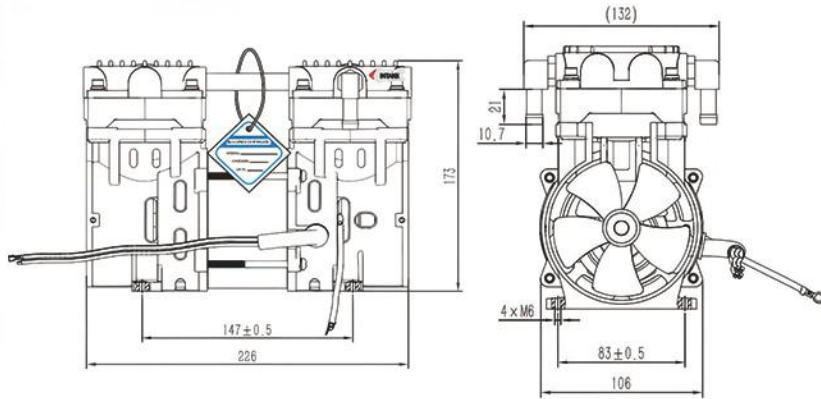

Technical Specification		
Model Number	HC280A-20/7	HC280B-25/7
Head configuration	Pressure parallel fow	Pressure parallel fow
Voltage	220V/50Hz/1	110V/60Hz/1
Power at rated pressure	≤340W	≤370W
Air flow rate	20L/min@700Kpa	25L/min@700Kpa
Speed at rated pressure	1400rpm	1700rpm
Dimension	226×118×173mm	226×118×173mm
Installation size	147×83mm	147×83mm
Net weight	6.8 kg	6.8 kg
Operating ambient air temperature	-5 to 40°C	-5 to 40°C
Thermal protection	145±5°C	145±5°C
Motor insulation class	F	F
Capacitor value	10μF	25μF

Performance Chart - Flow VS. Pressure

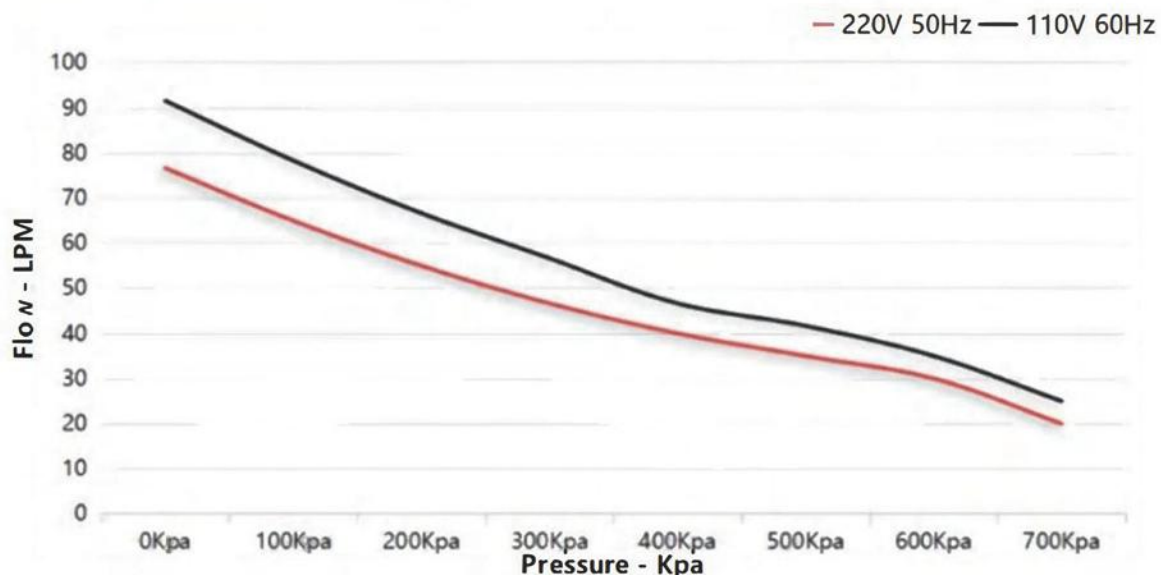

AC Oil Free Air Compressor

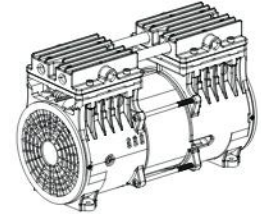
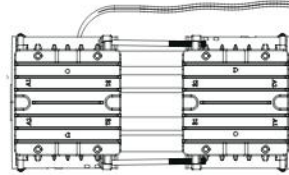
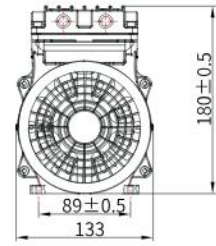
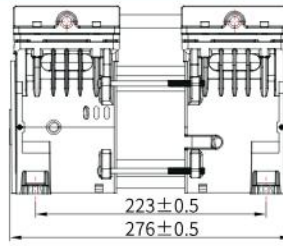

Technical Specification

	HC480A-40/7	HC480B-45/7
Model Number	HC480A-40/7	HC480B-45/7
Head configuration	Pressure parallel fow	Pressure parallel fow
Voltage	220V/50Hz/1	110V/60Hz/1
Power at rated pressure	≤480W	≤560W
Air flow rate	40L/min@700Kpa	45L/min@700Kpa
Speed at rated pressure	1400rpm	1700rpm
Dimension	276×133×180mm	276×133×180mm
Installation size	223×89mm	223×89mm
Net weight	9.8 kg	9.8kg
Operating ambient air temperature	-5 to 40°C	-5 to 40°C
Thermal protection	145±5°C	145±5°C
Motor insulation class	F	F
Capacitor value	15μF	60μF

Performance Chart - Flow VS. Pressure

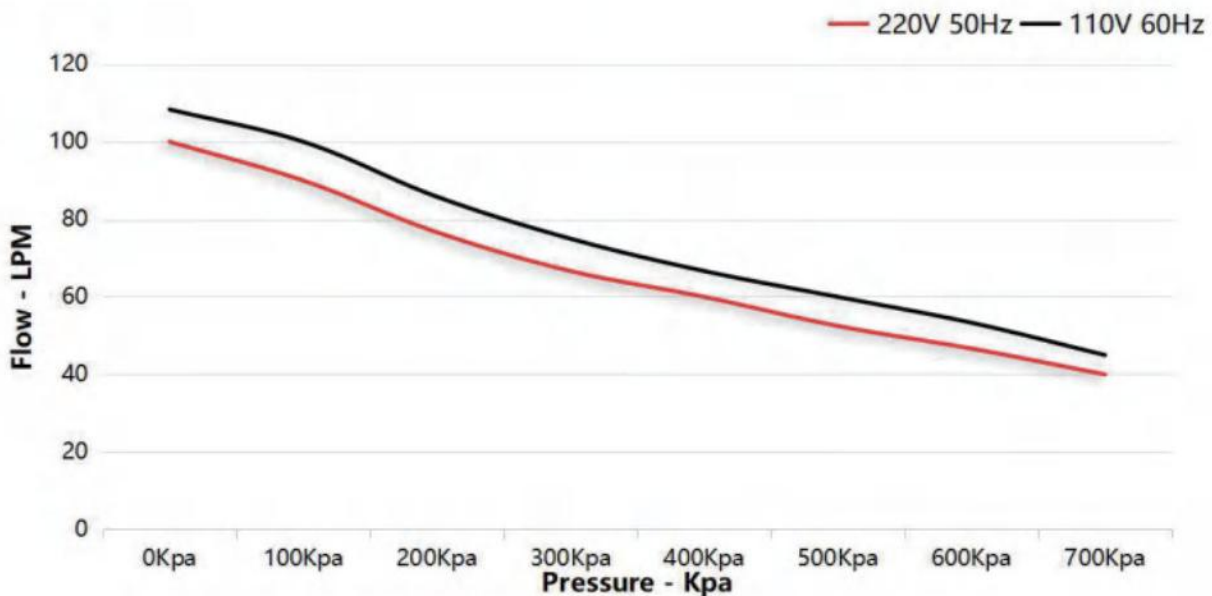

AC Oil Free Air Compressor

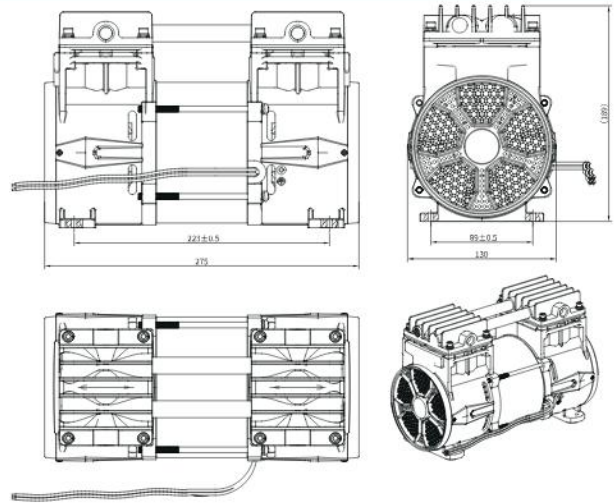

Technical Specification		
Model Number	HC550A-40/7	HC550B-45/7
Head configuration	Pressure parallel fow	Pressure parallel fow
Voltage	220V/50Hz/1	110V/60Hz/1
Power at rated pressure	≤480W	≤540W
Air flow rate	40L/min@700Kpa	45L/min@700Kpa
Speed at rated pressure	1400rpm	1700rpm
Dimension	275×130×189mm	275×130×189mm
Installation size	223×89mm	223×89mm
Net weight	8.5kg	8.5kg
Operating ambient air temperature	-5 to 40°C	-5 to 40°C
Thermal protection	145±5°C	145±5°C
Motor insulation class	F	F
Capacitor value	12.5μF	45μF

Performance Chart - Flow VS. Pressure

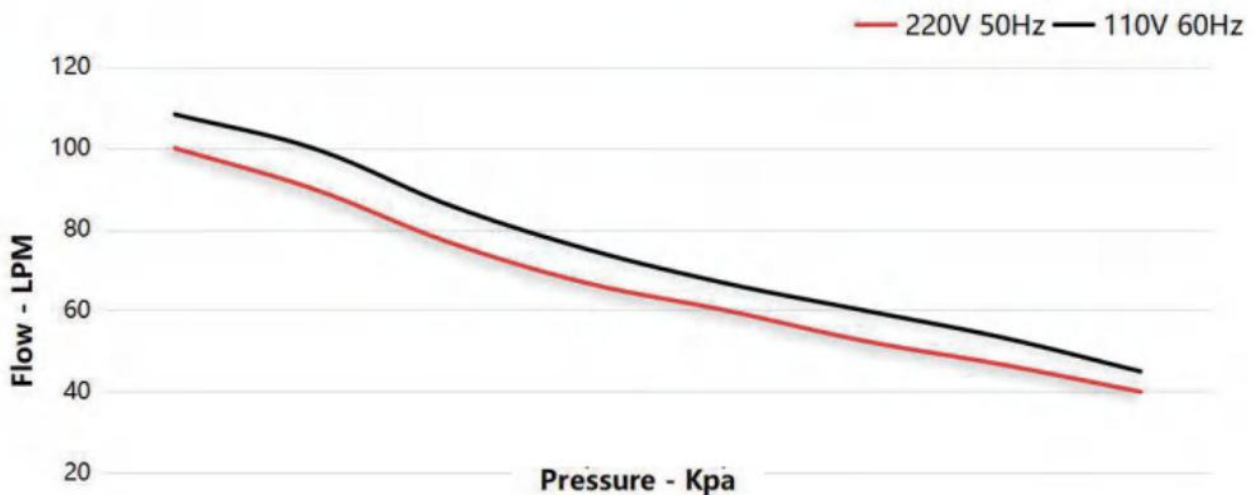

AC Oil Free Air Compressor

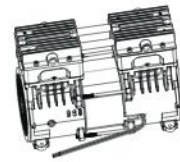
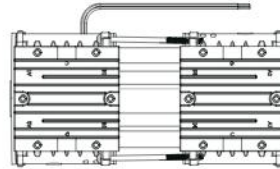
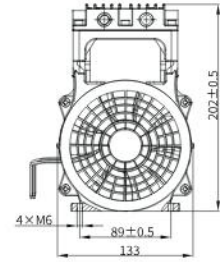
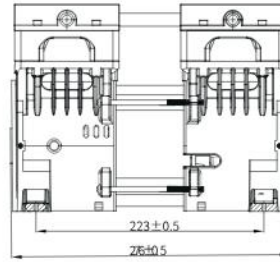
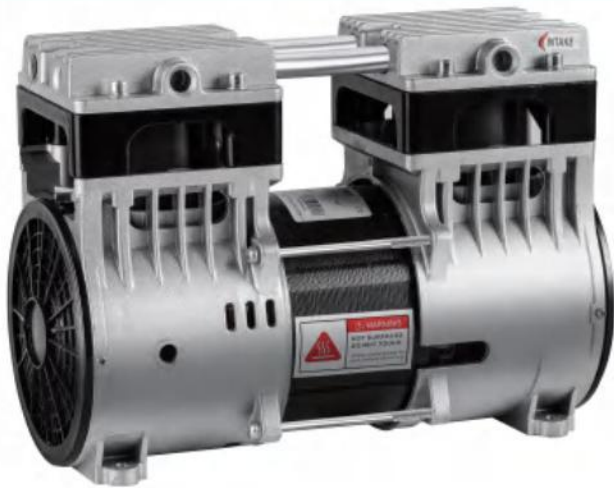

Technical Specification

	HC580A-60/7	HC580B-60/7
Model Number	HC580A-60/7	HC580B-60/7
Head configuration	Pressure parallel fow	Pressure parallel fow
Voltage	220V/50Hz/1	110V/60Hz/1
Power at rated pressure	≤690W	≤690W
Air flow rate	60L/min@700Kpa	60L/min@700Kpa
Speed at rated pressure	1400rpm	1700rpm
Dimension	276×133×202mm	276×133×202mm
Installation size	223×89mm	223×89mm
Net weight	10.1kg	10.1kg
Operating ambient air temperatur	-5 to 40℃	-5 to 40℃
Thermal protection	145±5℃	145±5℃
Motor insulation class	F	F
Capacitor value	20μF	60μF

Performance Chart - Flow VS. Pressure

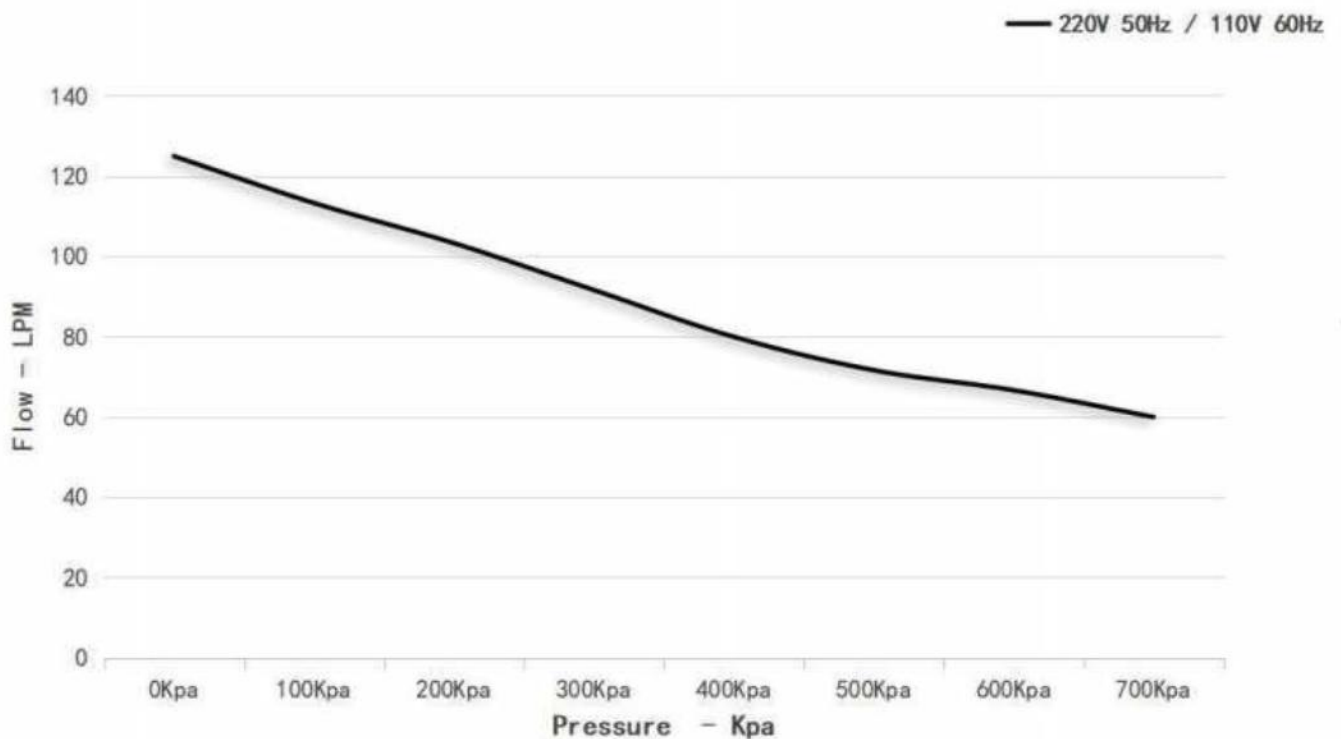

AC Oil Free Air Compressor

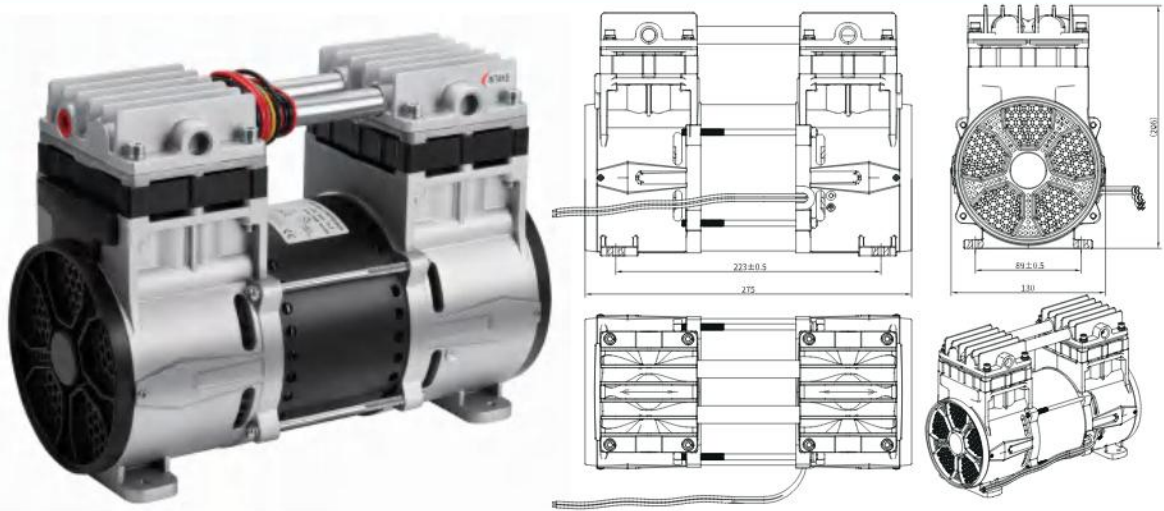

Technical Specification		
Model Number	HC680A-60/7	HC680B-60/7
Head configuration	Pressure parallel fow	Pressure parallel fow
Voltage	220V/50Hz/1	110V/60Hz/1
Power at rated pressure	≤610W	≤610W
Air flow rate	60L/min@700Kpa	60L/min@700Kpa
Speed at rated pressure	1400rpm	1700rpm
Dimension	275×130×206 mm	275×130×206 mm
Installation size	223×89mm	223×89mm
Net weight	9.9 kg	9.9 kg
Operating ambient air temperature	-5 to 40°C	-5 to 40°C
Thermal protection	145±5°C	145±5°C
Motor insulation class	F	F
Capacitor value	15μF	60μF

Performance Chart - Flow VS. Pressure

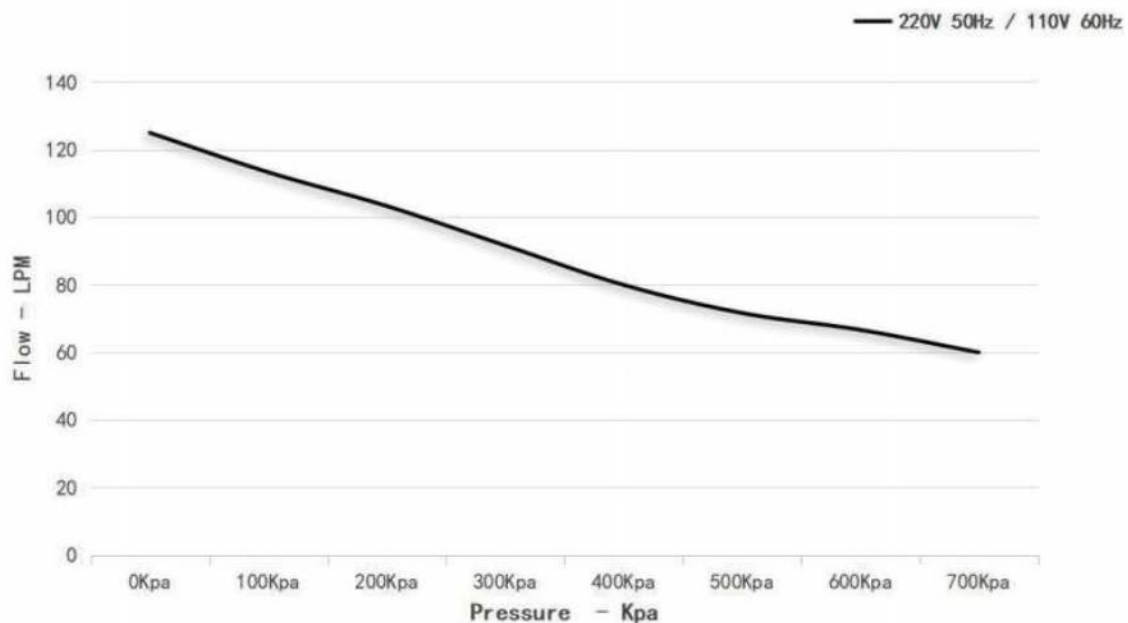

AC Oil Free Air Compressor

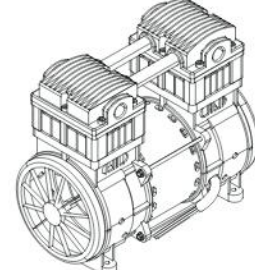
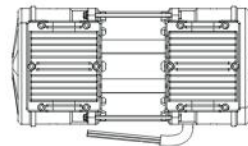
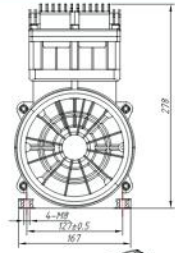
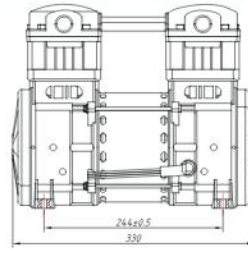

Technical Specification		
Model Number	HC1100A-100/8	HC1100B-100/8
Head configuration	Pressure parallel fow	Pressure parallel fow
Voltage	220V/50Hz/1	110V/60Hz/1
Power	≤1100W	≤1100W
Air flow rate	100L/min@800Kpa	100L/min@800Kpa
Speed at rated pressure	1400rpm	1700rpm
Dimension	330×167×278mm	330×167×278mm
Installation size	244×127mm	244×127mm
Net weight	17.2kg	17.2kg
Operating ambient air temperature	-5 to 40°C	-5 to 40°C
Thermal protection	145±5°C	145±5°C
Motor insulation class	F	F
Capacitor value	30μF	120μF

Performance Chart - Flow VS. Pressure

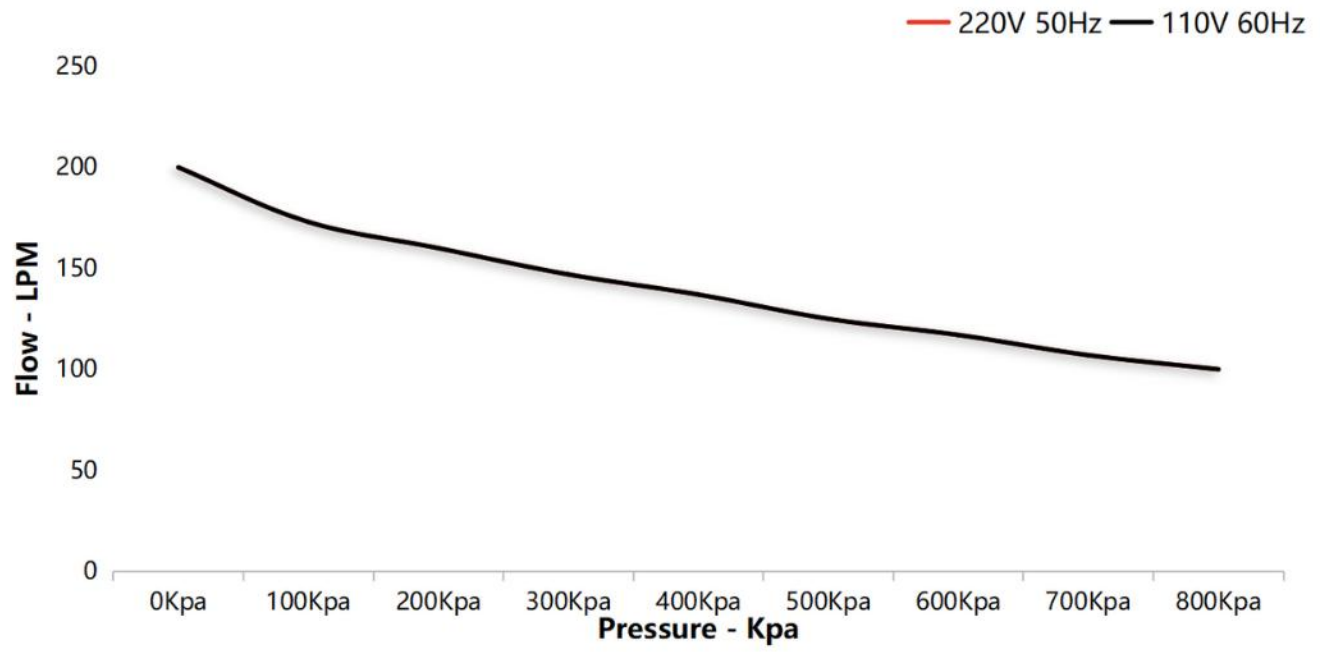

AC Oil Free Air Compressor

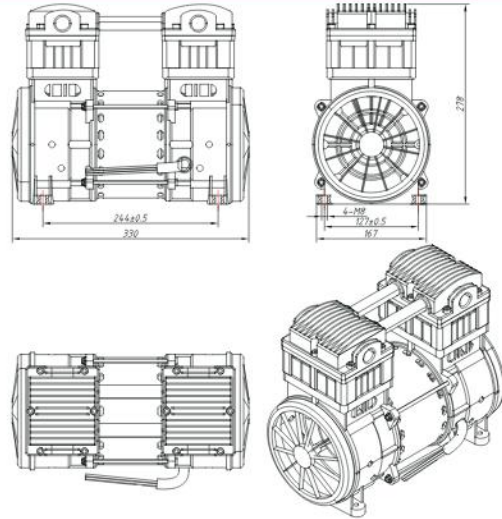

Technical Specification

	HC1500A-120/8	HC1500B-120/8
Model Number	HC1500A-120/8	HC1500B-120/8
Head configuration	Pressure parallel fow	Pressure parallel fow
Voltage	220V/50Hz/1	110V/60Hz/1
Power	≤1500W	≤1500W
Air flow rate	120L/min@800Kpa	120L/min@800Kpa
Speed at rated pressure	1400rpm	1700rpm
Dimension	330×167×278mm	330×167×278mm
Installation size	244×127mm	244×127mm
Net weight	17.5 kg	17.5 kg
Operating ambient air temperature	-5 to 40℃	-5 to 40℃
Thermal protection	145±5℃	145±5℃
Motor insulation class	F	F
Capacitor value	35μF	120μF

Performance Chart - Flow VS. Pressure

— 220V 50Hz / 110V 60Hz

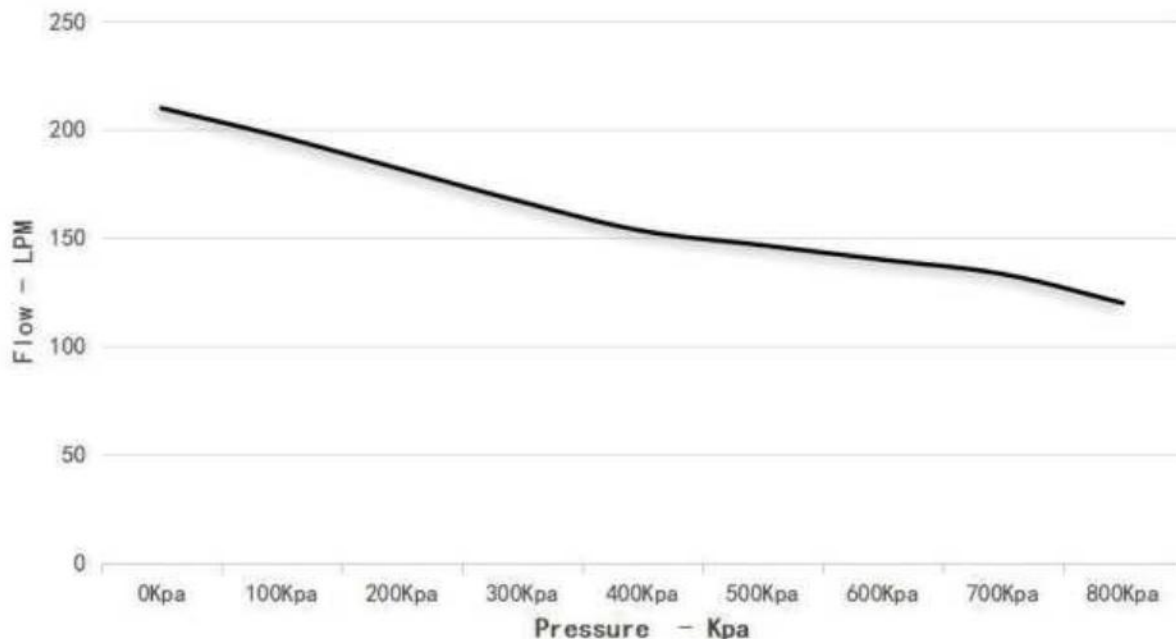

No	DESCRIPTION	Q'TY
1	SIDE COVER	2
2	LEFT FAN	2
3	ECCENTRIC WHEEL	2
4	BEARING OF ECCENTRIC WHEEL	2
5	MOUNT	2
6	CONNECT ROD	2
7	PISTON RING	2
8	FASTEN PLATE	2
9	CYLINDER	2
10	CYLINDER SEAL RING	2
11	METAL CUSHION	2
12	LIMITING PLSTE	2
13	INTAKE VALVE	2
14	VALVE PLATE	2
15	EXHAUST VALVE	2
16	REINFORCING PIECE	2
17	LIMITING PLSTE	2
18	SQUARE WASHER	2
19	O-RING GASKET-HEAD	2
20	CYLINDER COVER	2
21	"O" SEAL RING	4
22	CONNECT PIPE	2
23	REDUCE VIBRATION PILLARS	4

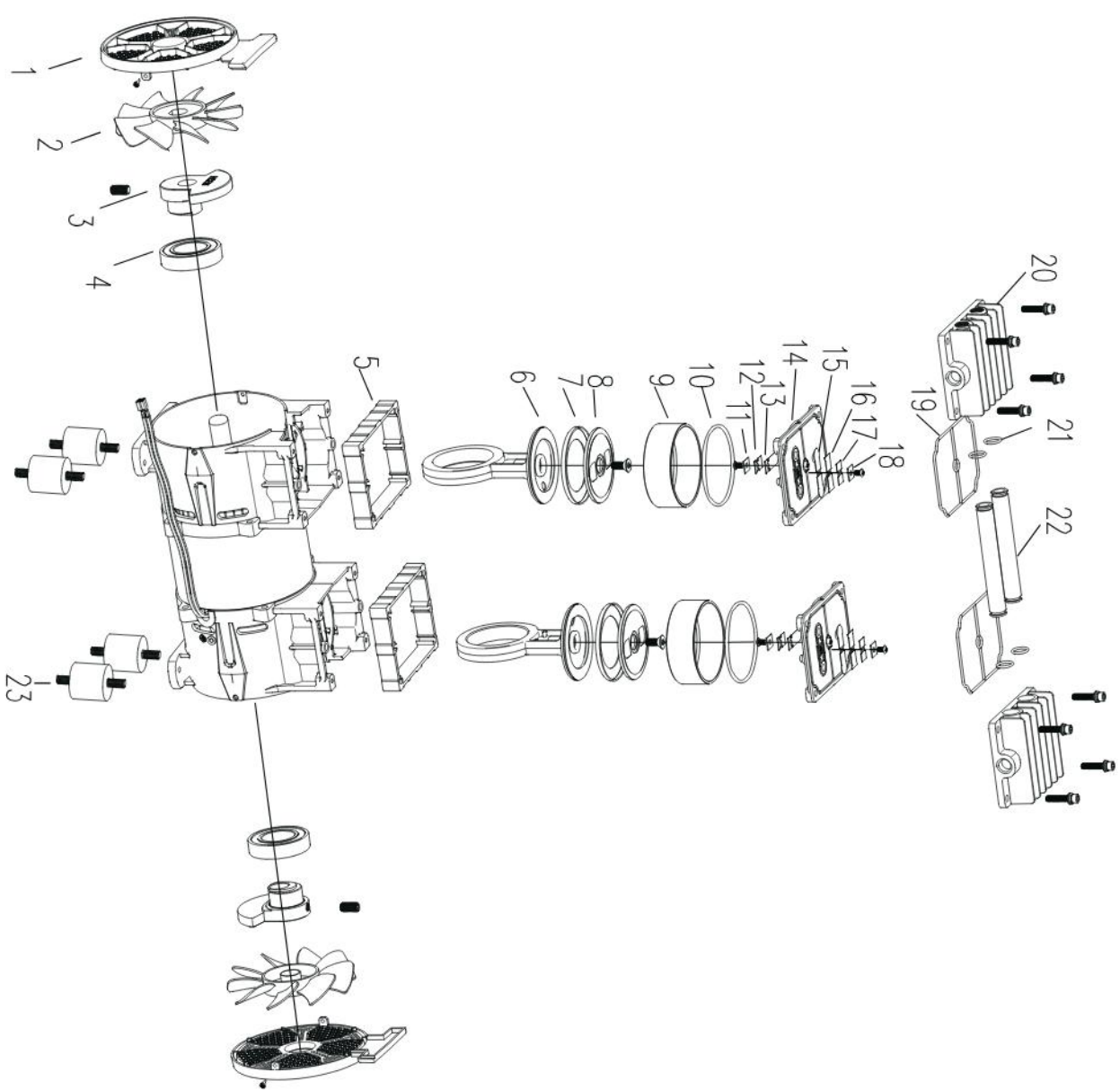

AC Oil Free Air Compressor

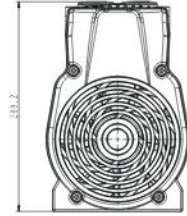
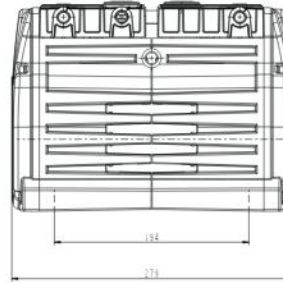
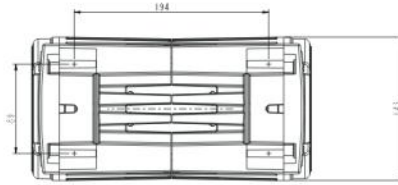

Technical Specification

Model Number	HC860A-40/10
Head configuration	Pressure parallel four
Voltage	220V/50Hz/1
Power	≤850W
Air flow rate	40L/min@1000Kpa
Speed at rated pressure	1400rpm
Dimension	279x143x209.2mm
Net weight	12.5 kg
Motor insulation class	F

Performance Chart - Flow VS. Pressure

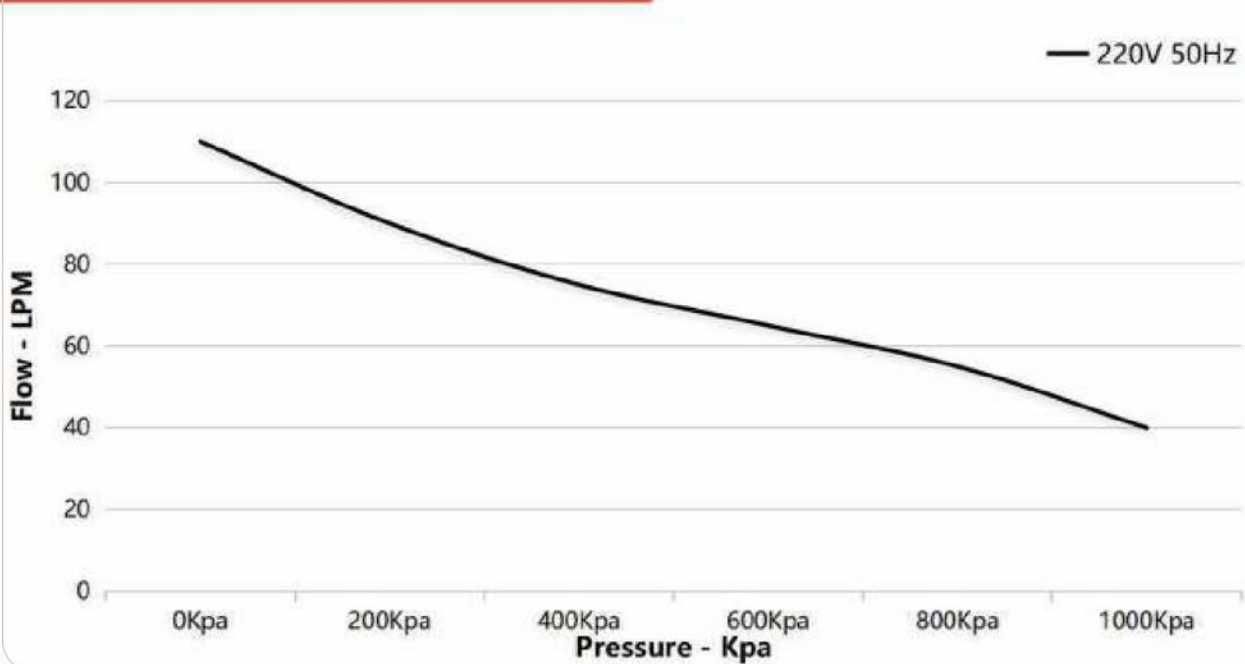

AC Oil Free Air Compressor

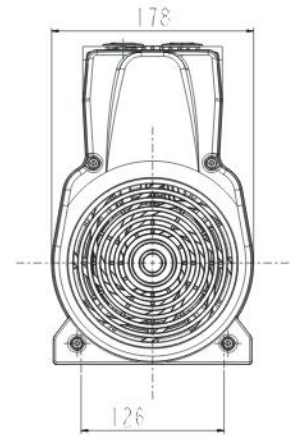
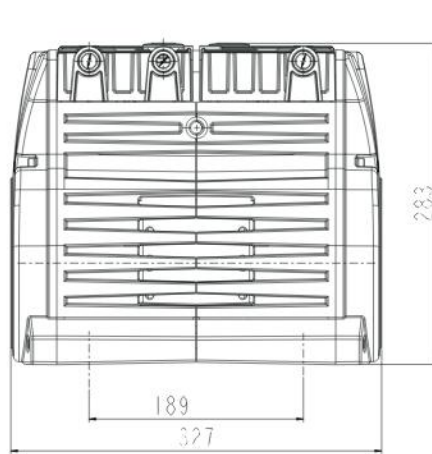

Technical Specification

Model Number	HC1800A-90/10
Head configuration	Pressure parallel fow
Voltage	220V/50Hz/1
Power	≤1700W
Air flow rate	90L/min@1000Kpa
Speed at rated pressure	1400rpm
Dimension	327x178x283mm
Net weight	21 kg
Motor insulation class	F

Performance Chart - Flow VS. Pressure

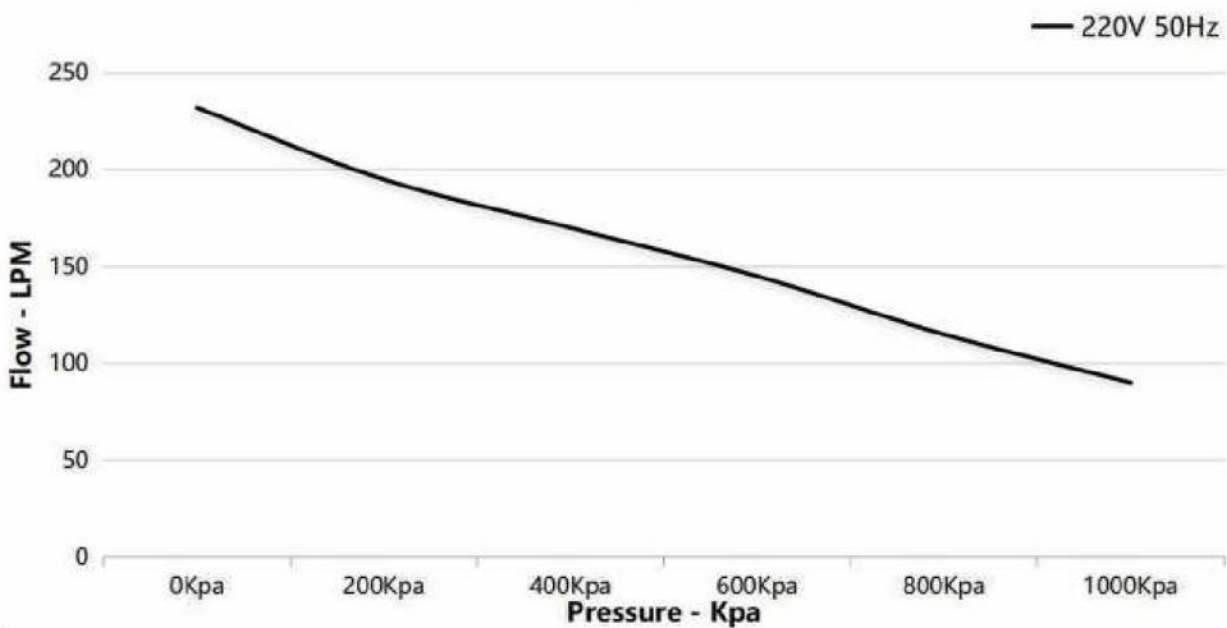

AC Oil Free Air Compressor

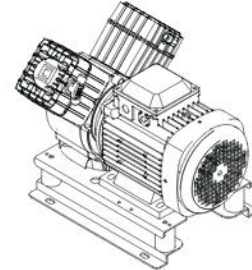
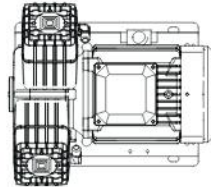
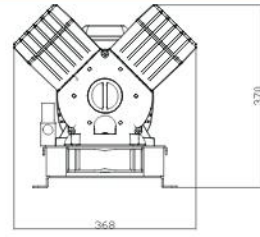
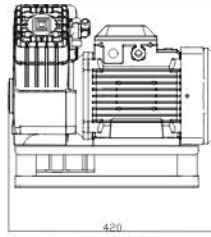

Technical Specification

	HC50 2V-90/10	HC50 2V-100/10
Model Number	HC50 2V-90/10	HC50 2V-100/10
Head configuration	Pressure parallel fow	Pressure parallel fow
Voltage	220V/50Hz/1	380V/50Hz/3
Power	≤1500W	≤1600W
Air flow rate	90L/min@1000Kpa	100L/min@1000Kpa
Speed at rated pressure	1400rpm	1400rpm
Dimension	385x375x320mm	385x375x320mm
Net weight	35 kg	32 kg
Motor insulation class	F	F

Performance Chart - Flow VS. Pressure

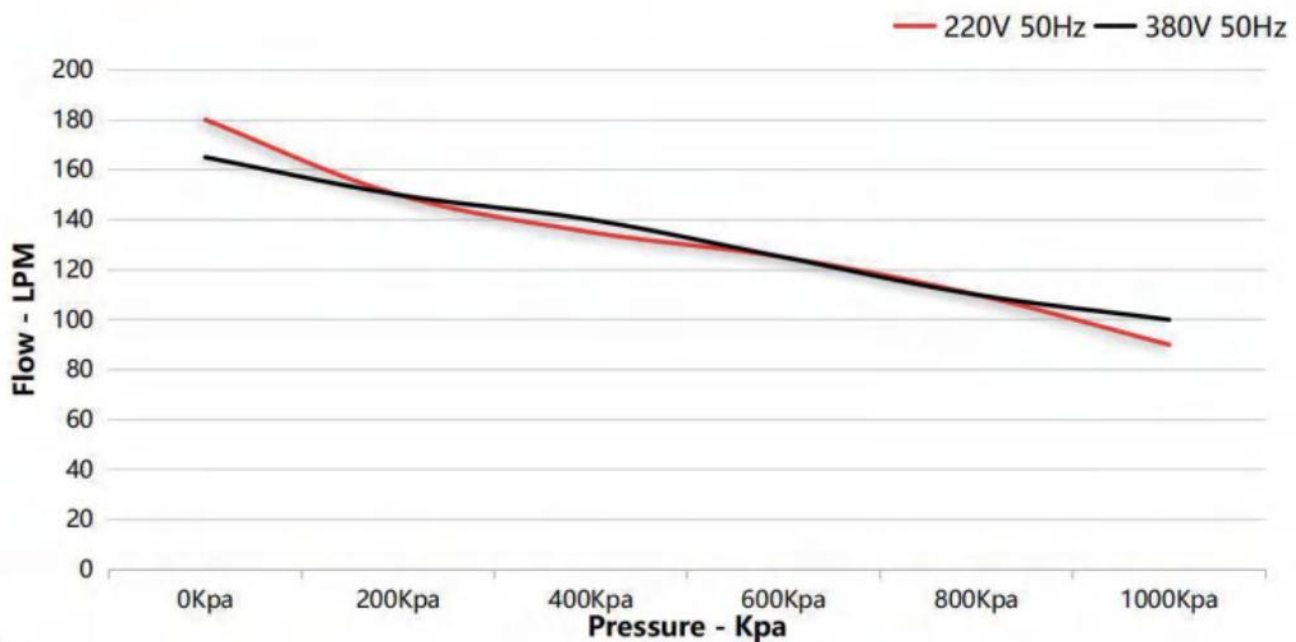

AC Oil Free Air Compressor

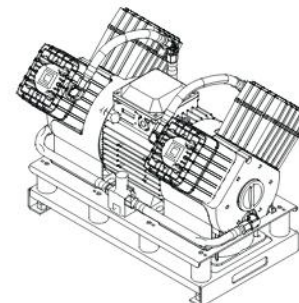
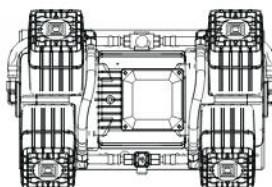
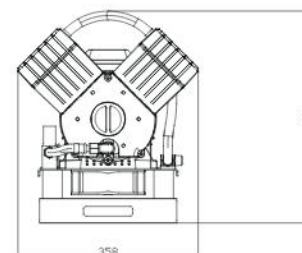
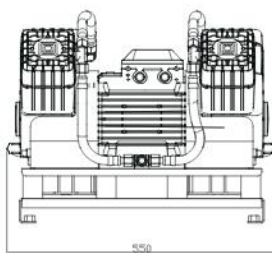

Technical Specification

	HC50 4V-270/10	HC50 4V-315/10
Model Number	HC50 4V-270/10	HC50 4V-315/10
Head configuration	Pressure parallel fow	Pressure parallel fow
Voltage	380V/50Hz/3	380V/50Hz/3
Power	≤3100W	≤3600W
Air flow rate	270L/min@1000Kpa	315L/min@1000Kpa
Speed at rated pressure	1400rpm	1400rpm
Dimension	550×358×432mm	550×358×432mm
Net weight	52.5 kg	52.5 kg
Motor insulation class	F	F

Performance Chart - Flow VS. Pressure

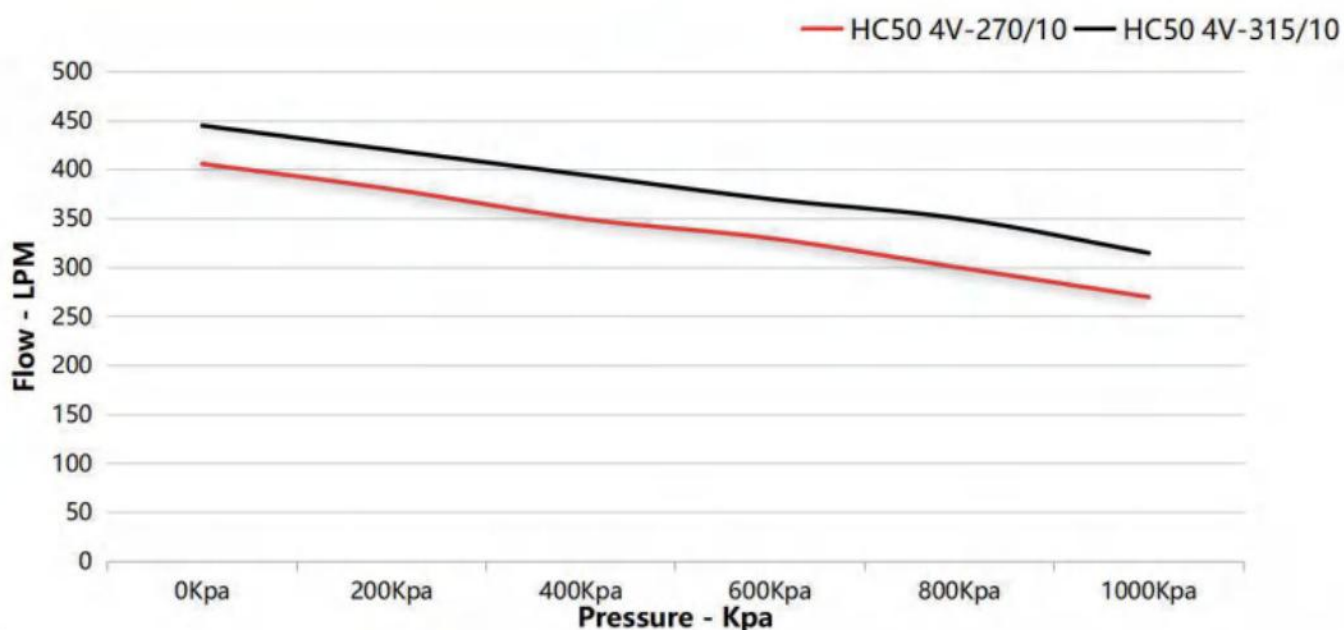

AC Oil Free Air Compressor

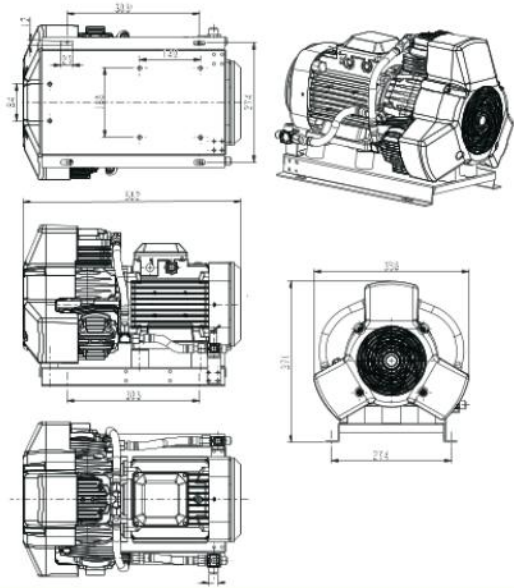

Technical Specification		
Model Number	HC60W3-200/10	HC60W3-220/10
Head configuration	Pressure parallel fow	Pressure parallel fow
Voltage	220V/50Hz/1	380V/50Hz/3
Power	≤2500W	≤2600W
Air flow rate	200L/min@1000Kpa	220L/min@1000Kpa
Speed at rated pressure	1400rpm	1400rpm
Dimension	502x357x371mm	502x357x371mm
Net weight	43 kg	37 kg
Motor insulation class	F	F

Performance Chart - Flow VS. Pressure

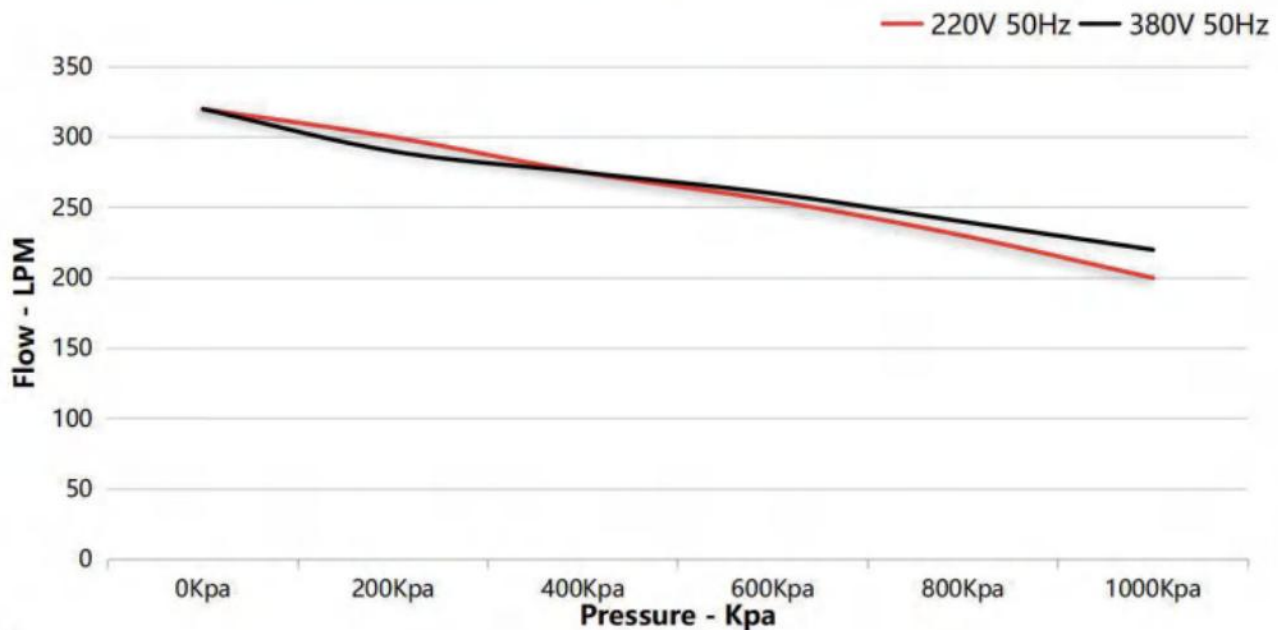

AC Oil Free Air Compressor

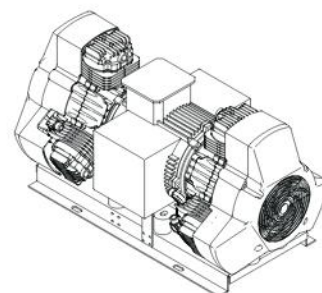
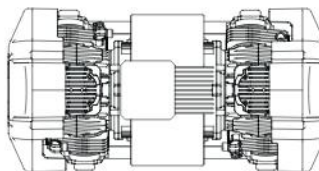
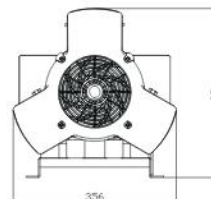
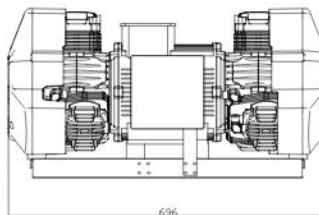

Technical Specification

Model Number	HC60W6-450/10
Head configuration	Pressure parallel fow
Voltage	380V/50Hz/3
Power	≤5200W
Air flow rate	450L/min@1000Kpa
Speed at rated pressure	1400rpm
Dimension	697x357x371mm
Net weight	69 kg
Motor insulation class	F

Performance Chart - Flow VS. Pressure

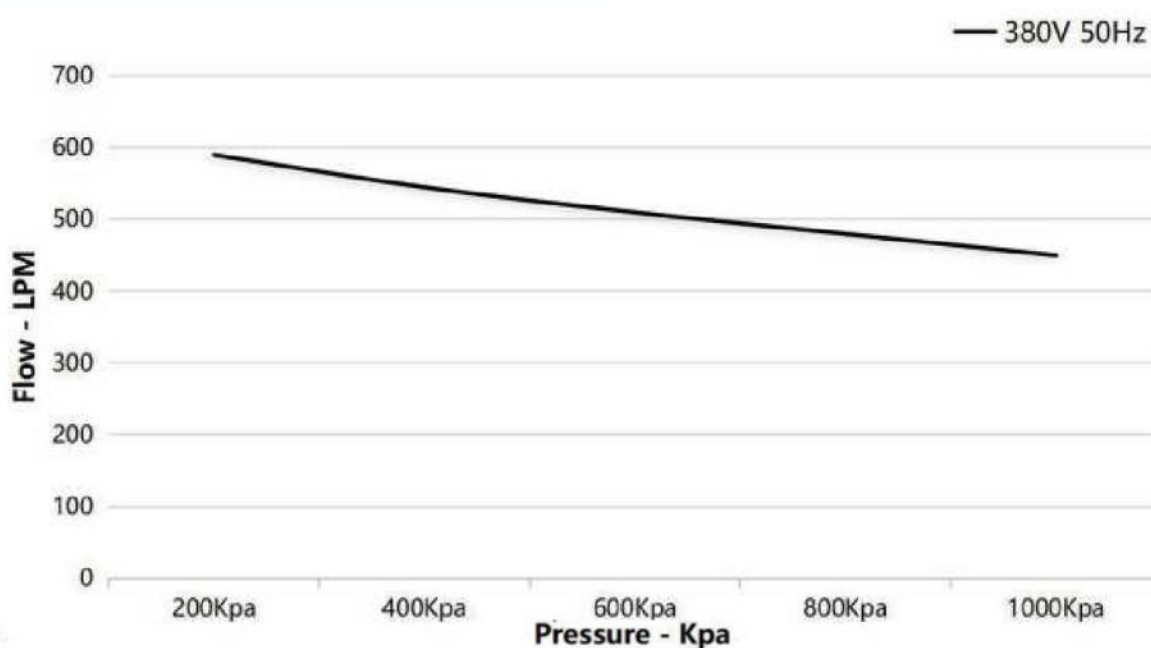

AC Oil Free Complete Machine



Technical Specification

Model	HC280AX
Voltage	220V /110V
Power	≤430W
Air flow rate	40L/min @ 6 bar
Net weight	18kg
Dimension	47.5*32*34 cm

Feature:

Oil free operation (maintenance free)

Low vibration & noise

Thermally protected motor

Imported consumable parts

24 hour continuous & stable output

Application :

Dental Equipment

AC Oil Free Complete Machine



Technical Specification		
Model	HC5501-6	HC7501-6
Voltage	220V /110V	
Power	470W 0.63 HP	680W 0.9 HP
Air flow rate	40L/min @ 700Kpa	60L/min @ 700Kpa
Net weight	18kg	18.5 kg
Dimension	40 * 30 * 36 cm	
Tank	6 liter	

Feature:

Oil free operation (maintenance free)
Low vibration & noise
Thermally protected motor
Imported consumable parts
24 hour continuous & stable output

Application:

Dental Equipment
Car Beauty
Flatbed Applicator

AC Oil Free Complete Machine



Technical Specification		
Model	HC5501-9	HC7501-9
Voltage	220V /110V	
Power	470W 0.63 HP	680W 0.9 HP
Air flow rate	40L/min @ 700Kpa	60L/min @ 700Kpa
Net weight	18.5kg	19kg
Dimension	64*27*55 cm	
Tank	9 liter	

Feature:

Oil free operation (maintenance free)
Low vibration & noise
Thermally protected motor
Imported consumable parts
24 hour continuous & stable output

Application:

Dental Equipment
Car Beauty

AC Oil Free Complete Machine



Technical Specification		
Model	HC5501-30	HC7501-30
Voltage	220V /110V	
Power	470W 0.63 HP	680W 0.9 HP
Air flow rate	40L/min @ 8 bar	60L/min @ 8 bar
Net weight	25kg	28kg
Dimension	43.5*43.5*71 cm	
Tank	30 liter	

Feature:

Oil free operation (maintenance free)
Low vibration & noise
Thermally protected motor
Imported consumable parts
24 hour continuous & stable output

Application:

Dental Equipment
Car Beauty

AC Oil Free Complete Machine



Technical Specification		
Model	HC5502-50	HC7502-50
Voltage	220V /110V	
Power	2*470W 1.25 HP	2*680W 1.81 HP
Air flow rate	80 L/min @ 8 bar	120 L/min @ 8 bar
Net weight	50kg	54kg
Dimension	75*48*86.5 cm	
Tank	50 liter	

Feature:

Oil free operation (maintenance free)

Low vibration & noise

Thermally protected motor

Imported consumable parts

24 hour continuous & stable output

Application:

Dental Equipment

Car Beauty

AC Oil Free Complete Machine



Technical Specification		
Model	HC5503-100	HC7503-100
Voltage	220V /110V	
Power	3*470W 1.88 HP	3*680W 2.72 HP
Air flow rate	120 L/min @ 8 bar	180 L/min @ 8 bar
Net weight	63kg	67kg
Dimension	87.5*48*86.5 cm	
Tank	100 liter	

Feature:

Oil free operation (maintenance free)
Low vibration & noise
Thermally protected motor
Imported consumable parts
24 hour continuous & stable output

Application:

Dental Equipment
Car Beauty

AC Oil Free Complete Machine



Technical Specification

Technical Specification		
Model	HC5504-120	HC7504-120
Voltage	220V /110V	
Power	4*470W 2.5 HP	4*680W 3.63 HP
Air flow rate	160 L/min @ 8 bar	240 L/min @ 8 bar
Net weight	86kg	90kg
Dimension	122x50x 90 cm	
Tank	120 liter	

Feature:

- Oil free operation (maintenance free)
- Low vibration & noise
- Thermally protected motor
- Imported consumable parts
- 24 hour continuous & stable output

Application:

- Dental Equipment
- Car Beauty

Silent Oil Free Air Compressor With Cabinet



Technical Specification		
Model	HC1530X	HC1730X
Voltage	220V /110V	
Power	470W 0.63 HP	680W 0.9 HP
Air flow rate	40L/min @ 8 bar	60L/min @ 8 bar
Noise	≤56dB(A)	
Net weight	62kg	65kg
Dimension	55*55*85 cm	
Tank	30 liter	

Feature:

Oil free operation (maintenance free) Dental Equipment

Low vibration & noise

Thermally protected motor

Imported consumable parts

Application:

Silent Oil Free Air Compressor With Cabinet



Technical Specification		
Model	HC 1100-50X	HC 1500-50X
Voltage	220V /110V	
Power	1100W 1.46 HP	1500W 2 HP
Air flow rate	100L/min @ 8 bar	120 L/min @ 8 bar
Noise	≤60dB(A)	
Net weight	91kg	95kg
Dimension	85*57*97 cm	
Tank	50 liter	

Feature:

Oil free operation (maintenance free)
Low vibration & noise
Thermally protected motor
Imported consumable parts
24 hour continuous & stable output

Application:

Dental Equipment

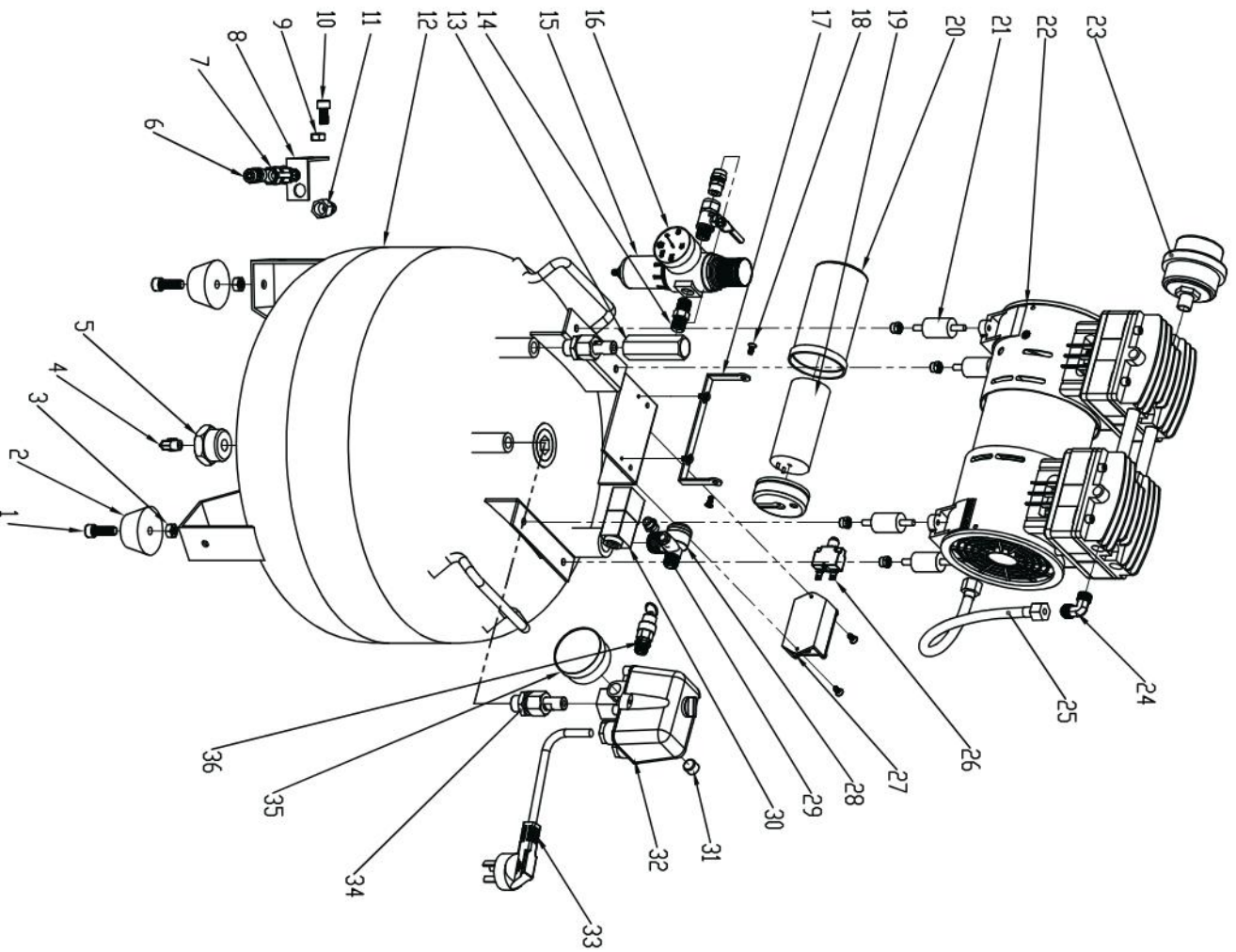

NUMBER	TYPE	QUANTITY
1	HEXAGON SOCKET HEAD CAP SCREW	3
2	SHOCK-ABSORBING FOOT PAD	3
3	GALVANIZED NUT	3
4	OUTER WIRE ELBOW QUINCY TWIST	1
5	PATCH ADAPTER STRAIGHT CONNECTOR Ø1/2"	1
6	TWIST CONNECTOR	2
7	BRASS BALL VALVE	2
8	DRAIN VALVE BRACKET	1
9	ANTI-LOOSENING NUT	5
10	HEXAGON SOCKET SCREW INTERNAL THREAD STRAIGHT CONNECTOR	1
11	AIR TANK	1
12	DIRECT CONNECTION	1
13	CONNECTOR	1
14	PRESSURE REGULATING VALVE	1
15	Y40 AXIAL PRESSURE GAUGE	1
16	CAPACITOR BOX BRACKET	1
17	FLAT MACHINE SCREW	1
18	CAPACITOR	6
19	CAPACITOR BOX	1
20	RUBBER SHOCK ABSORBER FEET	4
21	COMPRESSOR ENGINE	1
22	SILENCING FILTER	1
23	ELBOW	1
24	METAL HOSE	1
25	OVERLOAD PROTECTOR	1
26	PROTECTOR BOX	1
27	ONE-WAY VALVE	1
28	CONNECTOR	1
29	SOLENOID VALVE	1
30	PLUG	1
31	PRESSURE SWITCH	1
32	POWER SUPPLY CORD	1
33	ADAPTER	1
34	Y40 AXIAL PRESSURE GAUGE	2
35	SAFETY VALVE	1
36		1

Accessories



Capacitor



Elbow



Silencer



Piston ring



Rubber feet



Cylinder



Safety valve



Check valve



Ball valve



Plug



Caster



Pressure switch



Solenoid valve



Oil-water separator



Caster screws



Quick connector



Metal hose



Pressure gauge



Drain valve



Line damping feet



Capacitor cap



Overload protector motor

HCEM · 浙江鸿川动力

HONGCHUAN POWER TECHNOLOGY CO.,LTD



web



alibaba web



 YouTube

Tell: (0579) 8539 5979 Fax: (0579) 8539 5960

Add: No. 636 Guangshun Street, Xiaoshun Town, Jindong District,
Jinhua , Zhejiang ,China,321036

www.hcempump.com