

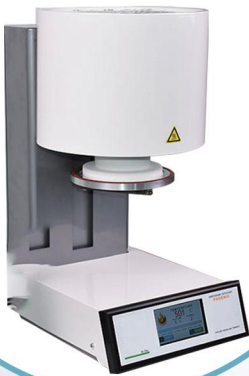

**Vacuum Pump**



**浙江鸿川医疗科技有限公司**

**Zhejiang Hongchuan Medical Technology Co.,Ltd**



## Company Introduction:

Zhejiang Hongchuan Medical Technology Co.,Ltd was first established in 2010 , which is a large-scale enterprise group ,we are specializing in R&D and manufacturing various kinds of air compressor , vacuum pump and automatic disinfection machine .

Our products mainly serve industries such as medical equipment, dental equipment ,robotic arms, automation equipment, beauty equipment, packaging equipment, new energy vehicles and pond aeration systems etc .

Dedicated to strict quality control and thoughtful customer service, our experienced engineers are always available to discuss your requirements and ensure full customer satisfaction. From the structural design , appearance design and mold development are all done by our own R&D team .

For all products ,we all have 2-5 years quality warranty .We have a very rigid inspection process , and all goods need 3 times QC inspection, so we can make sure good quality.

Our company don't have complicated application process, so if you have any requirement, we can react much faster without waiting for application result for a long time.

Our products are sold well in all cities and provinces around China, and also exported to USA , Germany ,UK , Italy ,Spain ,New Zealand, Australia , Russia , Indonesia and South Korea etc.

We are welcome the OEM and ODM orders. Whether selecting a current product from our catalog or seeking engineering assistance for your application, you can talk to our customer service center about your sourcing requirements.

Adhering to the business principle of mutual benefits, we have had a reliable reputation among our customers because of our professional services, quality products and competitive prices.

If you have questions or thoughts , please contact us freely. Most of our customers have 30-50% increase of business every year, we hope we can also help your business grow, and let's grow together.



# Authorization

## Certificates



## Utility Patents



# Application



**Vacuum Packaging Machine**



**Sputum Aspirator**

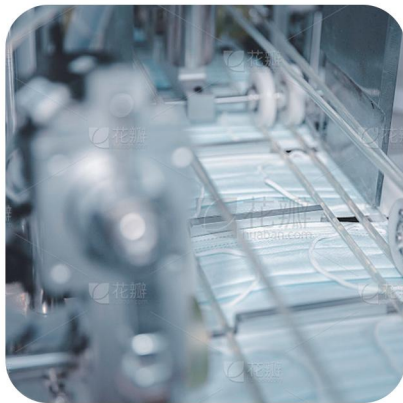

**Medical Device Aroduction Line**



**Beauty Machine**

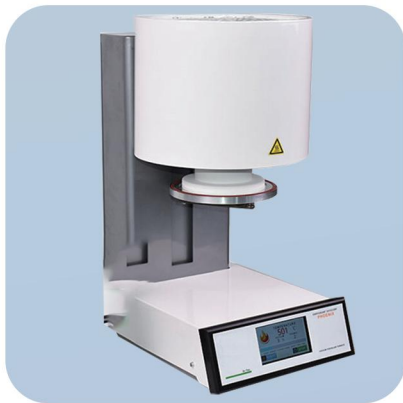

**Dental Porcelain Furnace**

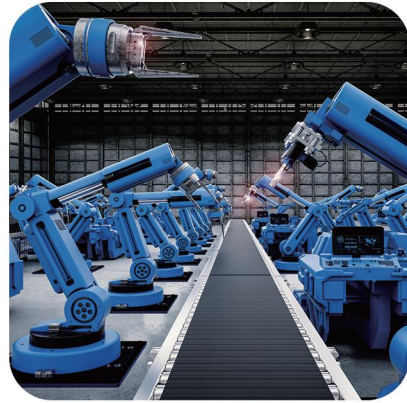

**Mechanical Arm**



**Laboratory**



**Defoaming Machine**



# AC Oil Free Vacuum Pump

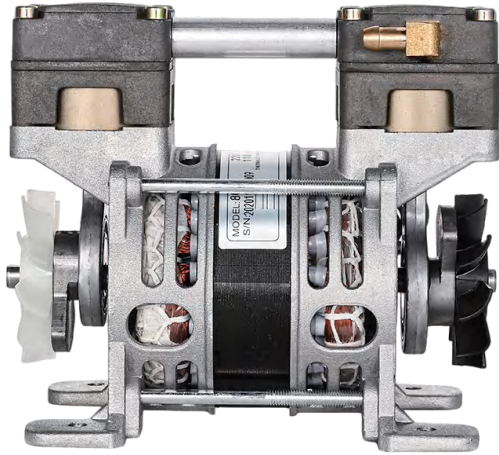

**HC80A2**

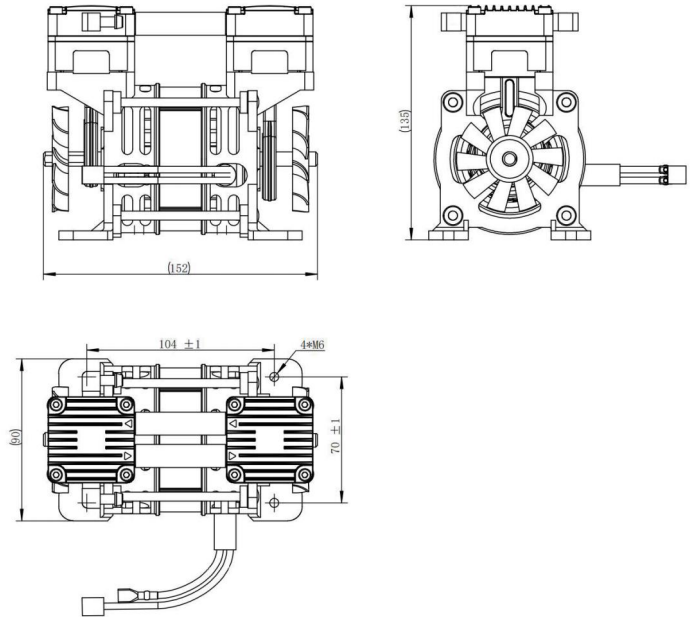

Technical Specification		
<b>Model</b>	HC80A2	HC80C2
<b>Installation size</b>	70*104mm(M6X4)	46*78mm(M6X4)
<b>Vacuum flow rate</b>	30L/min @-86Kpa	
	15L/min @-95Kpa	
<b>Dimension</b>	152*90*135mm	150*95*135mm
<b>Voltage</b>	220V /110V	
<b>Power</b>	90W	
<b>Rated speed</b>	1400rpm/1700rpm	
<b>Noise</b>	≤52dB(A)	
<b>Packing</b>	Carton case	
<b>Net weight</b>	2.25kg	
<b>Use environment</b>	-5-40°C	

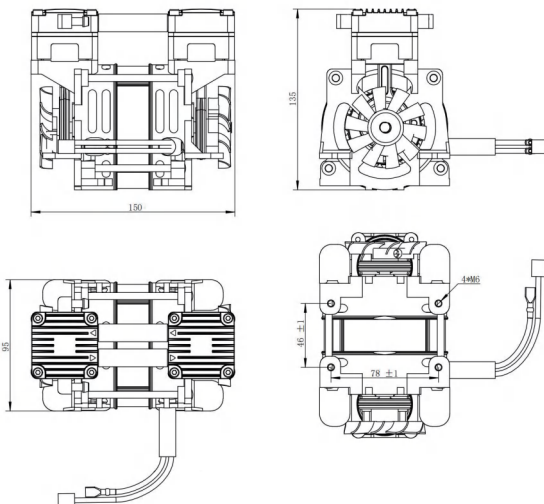

**HC80C2**

# AC Oil Free Vacuum Pump



**HC100A2**



**HC100A2-1**

## Technical Specification

Model	HC100A2	HC100A2-1
Installation size	70*114 mm(M6X4)	
Vacuum flow rate	40L/min@-87Kpa	
	20L/min@-97Kpa	
Dimension	176*90*143mm	
Voltage	220V/110V	
Power	≤100W	
Rated speed	1400rpm/1700rpm	
Noise	≤52dB(A)	
Packing	Carton case	
Net weight	3.43kg	
Use environment	-5℃-40℃	

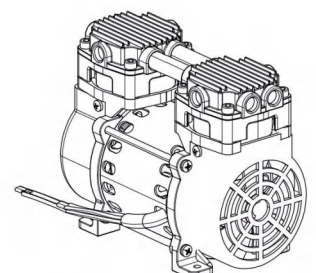
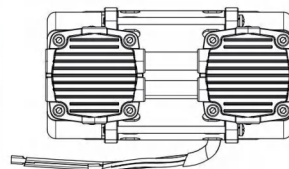
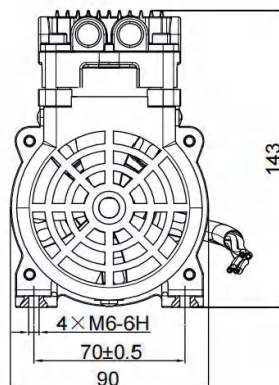
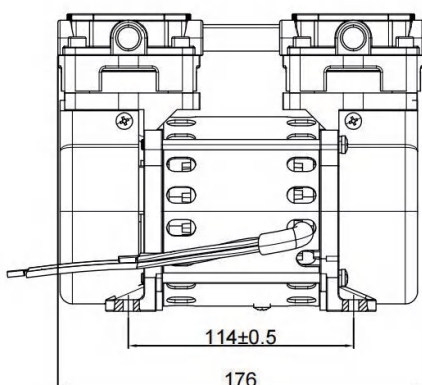

# AC Oil Free Vacuum Pump



**HC280A2**



**HC280A2-1**

## Technical Specification

Model	HC280A2	HC280A2-1
Installation size	83*147 mm(M6X4)	
Vacuum flow rate	75L/min@-90Kpa	
	37L/min@-97Kpa	
Dimension	245*104*167 mm	
Voltage	220V/110V	
Power	≤250W	
Rated speed	1400rpm/1700rpm	
Noise	≤55dB(A)	
Packing	Carton case	
Net weight	6.05kg	
Use environment	-5°C-40°C	

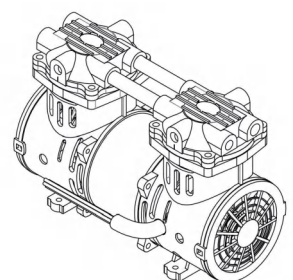
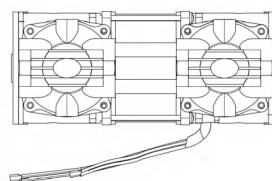
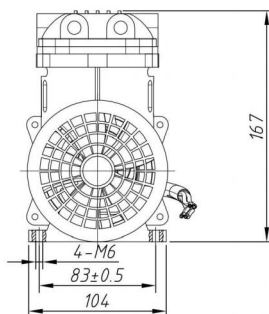
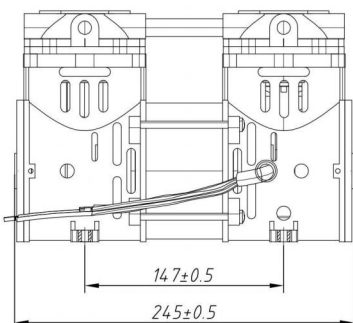



# AC Oil Free Vacuum Pump

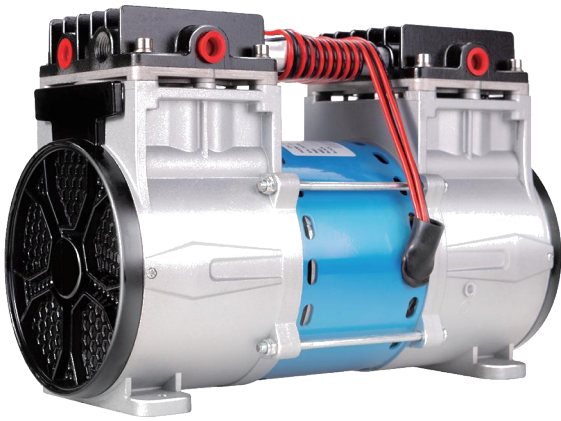

**HC550A2**



**HC550A2-1**

## Technical Specification

Model	HC550A2	HC550A2-1
Installation size	89*223 mm(M6X4)	
Vacuum flow rate	110Lmin@-92Kpa	
	55L/min@-98Kpa	
Dimension	276*130*190 mm	
Voltage	220V /110V	
Power	≤380W	
Rated speed	1400rpm/1700rpm	
Noise	≤55dB(A)	
Packing	Carton case	
Net weight	8.86 kg	
Use environment	-5°C-40°C	

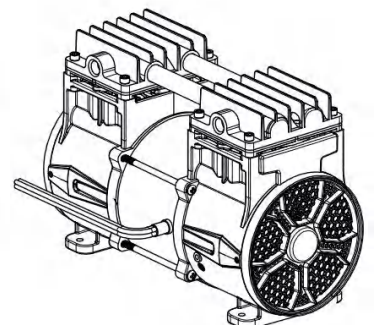
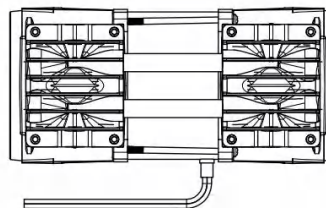
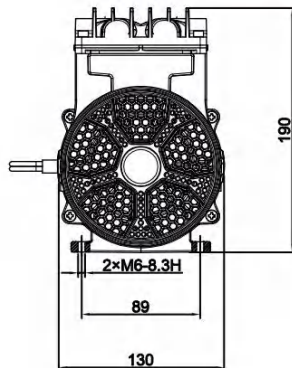
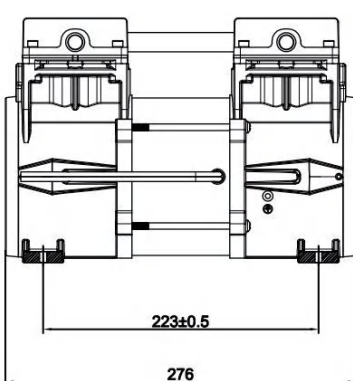



# AC Oil Free Vacuum Pump



**HC750A2**



**HC750A2-1**

Technical Specification		
<b>Model</b>	HC750A2	HC750A2-1
<b>Installation size</b>	89*223 mm(M6X4)	
<b>Vacuum flow rate</b>	140 L/min@-92Kpa	
	70 L/min@-98Kpa	
<b>Dimension</b>	276*130*206mm	
<b>Voltage</b>	220V /110V	
<b>Power</b>	≤500W	
<b>Rated speed</b>	1400rpm/1700rpm	
<b>Noise</b>	≤60dB(A)	
<b>Packing</b>	Carton case	
<b>Net weight</b>	9.5 kg	
<b>Use environment</b>	-5℃-40℃	

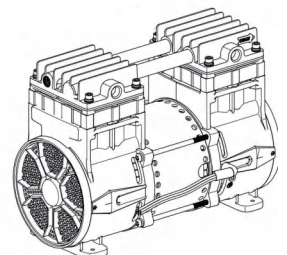
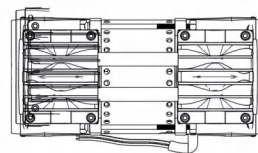
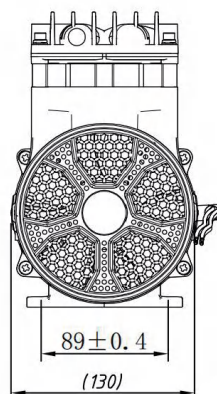
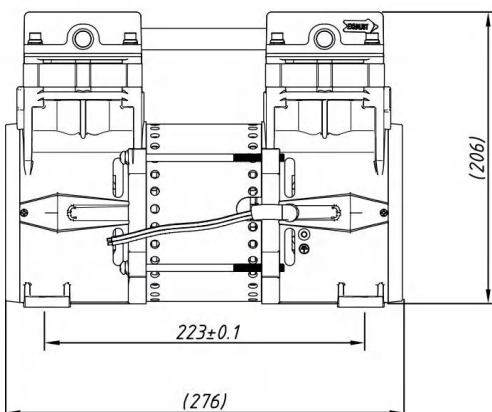

# AC Oil Free Vacuum Pump

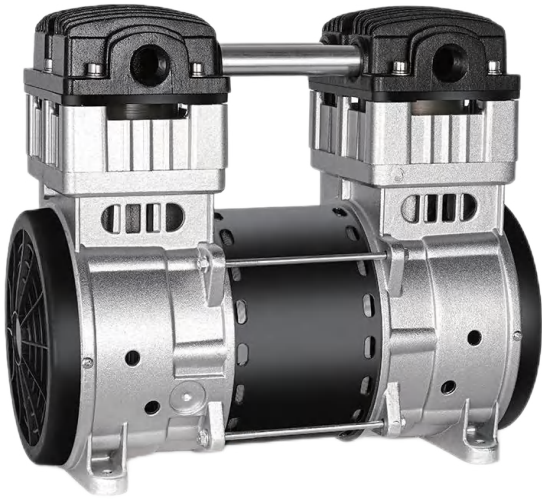

**HC1100A2**



**HC1100A2-1**

Technical Specification		
<b>Model</b>	HC1100A2	HC1100A2-1
<b>Installation size</b>	127*244 mm(M8X4)	
<b>Vacuum flow rate</b>	200L/min @ -93Kpa	
	100 L/min@-98Kpa	
<b>Dimension</b>	330*167*278 mm	
<b>Voltage</b>	220V /110V	
<b>Power</b>	≤600W	
<b>Rated speed</b>	1400rpm/1700rpm	
<b>Noise</b>	≤65dB(A)	
<b>Packing</b>	carton case	
<b>Net weight</b>	17.115kg	
<b>Use environment</b>	-5℃-40℃	

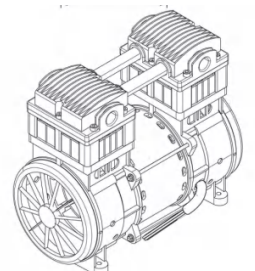
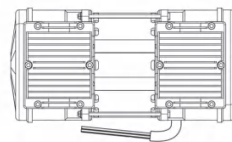
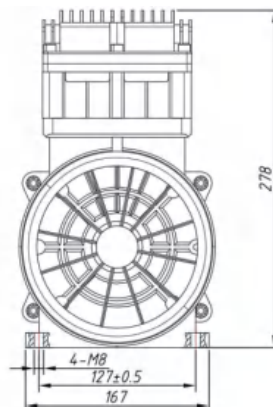
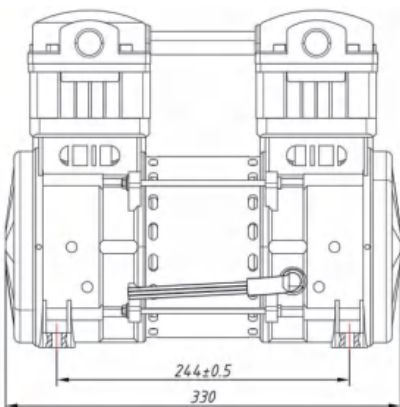



# AC Oil Free Vacuum Pump



**HC1500A2**



**HC1500A2-1**

## Technical Specification

Model	HC1500A2	HC1500A2-1
Installation size	127*244 mm(M8X4)	
Vacuum flow rate	220 L/min@-94Kpa	
	150 L/min@-98Kpa	
Dimension	330*167*278 mm	
Voltage	220V /110V	
Power	≤700W	
Rated speed	1400rpm/1700rpm	
Noise	≤65dB(A)	
Packing	Carton case	
Net weight	17.64 kg	
Use environment	-5°C-40°C	

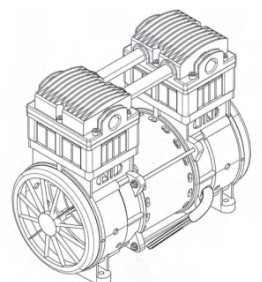
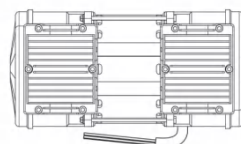
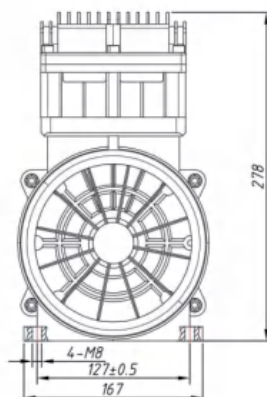
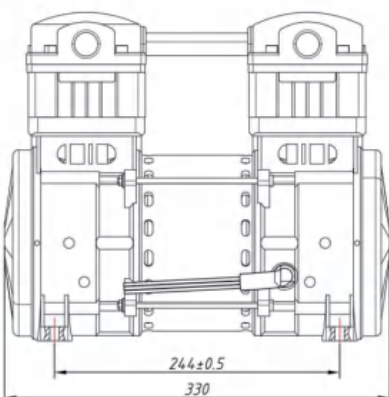

# DC Oil Free Vacuum Pump

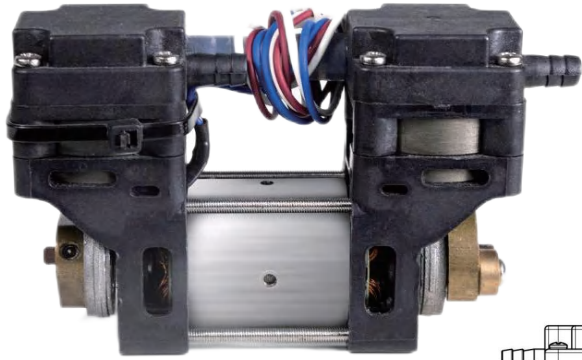

**HC30C2**

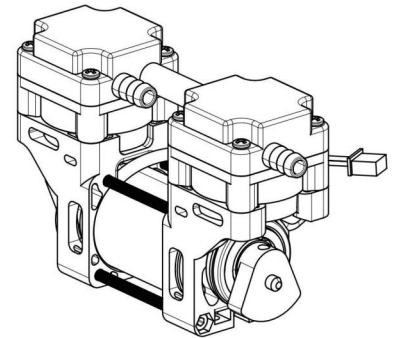
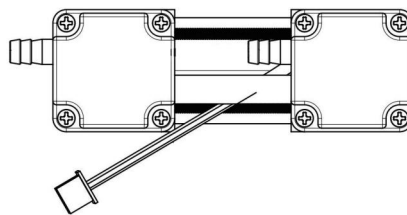
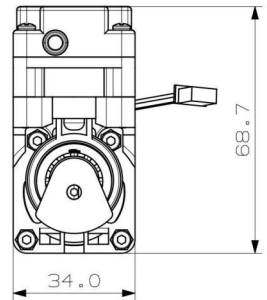
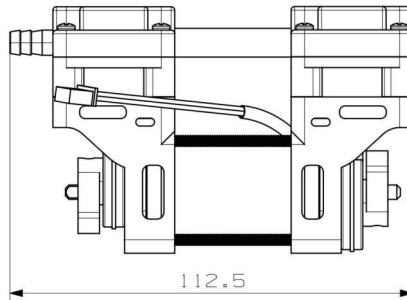

Technical Specification	
<b>Model</b>	HC30C2
<b>Installation size</b>	52.4X13.5mm (φ3.3X4)
<b>Vacuum flow rate</b>	9.5L/min @-92Kpa
<b>Dimension</b>	112.5×34×68.7 mm
<b>Nominal voltage input</b>	DC16.8V
<b>Power</b>	≤18W
<b>Rated speed</b>	≤1950rpm
<b>Noise</b>	≤48dB(A)
<b>Packing</b>	300pcs / pallet
<b>Net weight</b>	0.395 kg
<b>Use environment</b>	-5℃-40℃
<b>Accessories</b>	1x Controller



# DC Oil Free Vacuum Pump



**HC100D2**

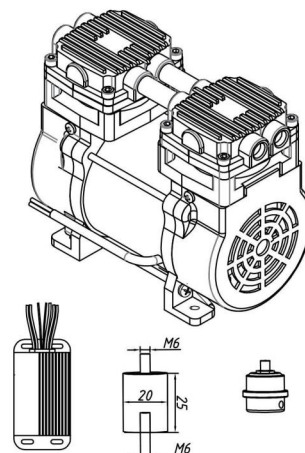
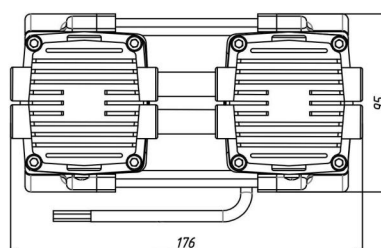
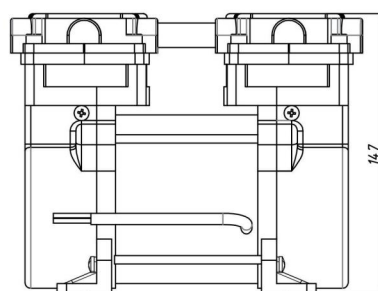

## Technical Specification

<b>Model</b>	HC100D2
<b>Installation size</b>	70*114 mm (M6X4)
<b>Vacuum flow rate</b>	60 L/min @ -92 Kpa
	30 L/min @ -98 Kpa
<b>Dimension</b>	176*95*147 mm
<b>Voltage</b>	DC12V /24V /48V
<b>Power</b>	≤90W
<b>Rated speed</b>	≤1450rpm
<b>Noise</b>	≤52dB(A)
<b>Packing</b>	Carton case
<b>Net weight</b>	2.8 kg
<b>Use environment</b>	-5℃-40℃
<b>Accessories</b>	1x Controller ,4x Rubber Feet ,1x air Filter

# DC Oil Free Vacuum Pump

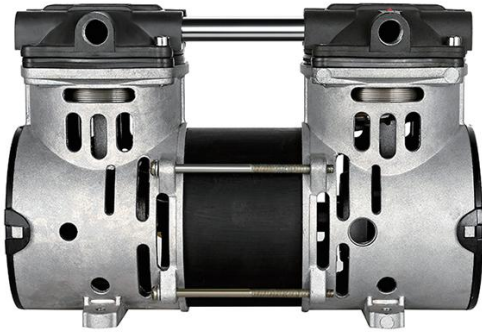

**HC280D2**

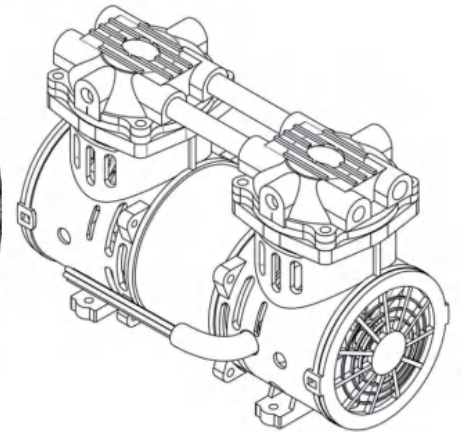
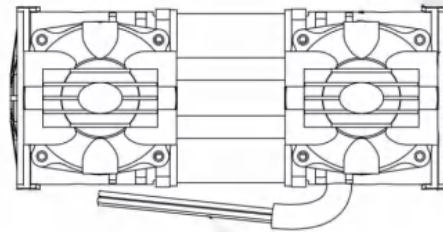
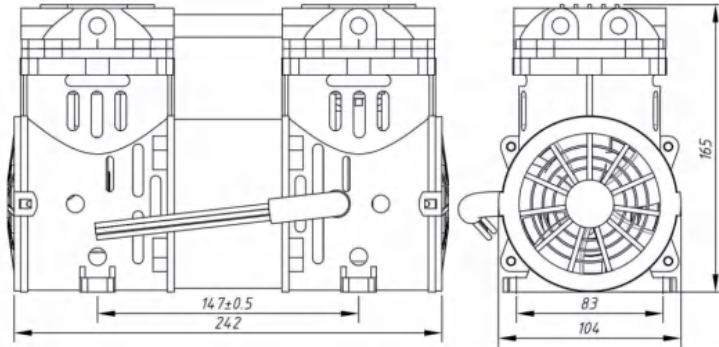

## Technical Specification

<b>Model</b>	HC280D2
<b>Installation size</b>	83*147 mm(M6X4)
<b>Vacuum flow rate</b>	83 L/min @ -90Kpa
	40 L/min @ -98Kpa
<b>Dimension</b>	242*104*165 mm
<b>Voltage</b>	DC12V /24V /48V
<b>Power</b>	≤180W
<b>Rated speed</b>	≤1450rpm
<b>Noise</b>	≤55dB(A)
<b>Packing</b>	Carton case
<b>Net weight</b>	4.9kg
<b>Use environment</b>	-5℃ -40℃
<b>Accessories</b>	1x Controller ,4x Rubber Feet ,1x air Filter



# DC Oil Free Vacuum Pump

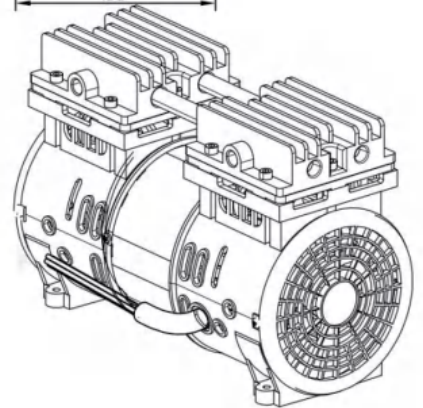
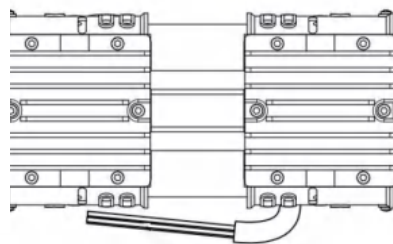
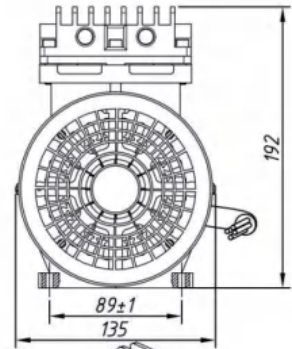
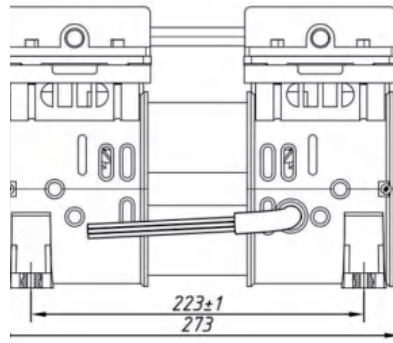
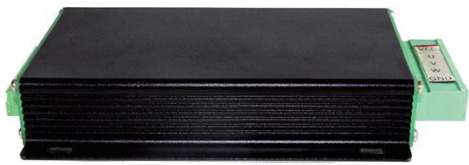

**HC550D2**

## Technical Specification

<b>Model</b>	HC550D2
<b>Installation size</b>	89*223 mm(M6X4)
<b>Vacuum flow rate</b>	100 L/min @ -93 Kpa
	50 L/min @ -98 Kpa
<b>Dimension</b>	273*135*192 mm
<b>Voltage</b>	DC12V /24V /48V
<b>Power</b>	≤320W
<b>Rated speed</b>	≤1450rpm
<b>Noise</b>	≤55dB(A)
<b>Packing</b>	Carton case
<b>Net weight</b>	9.95 kg
<b>Use environment</b>	-5℃-40℃
<b>Accessories</b>	1x Controller ,4x Rubber Feet ,1x air Filter

# DC Oil Free Vacuum Pump

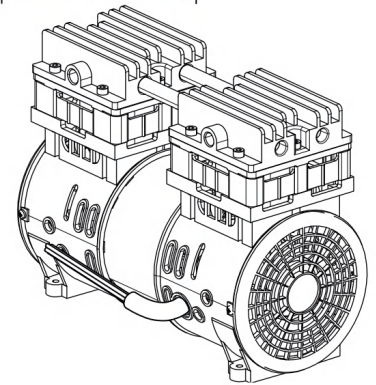
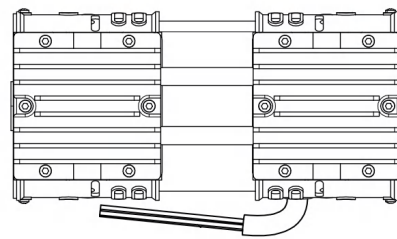
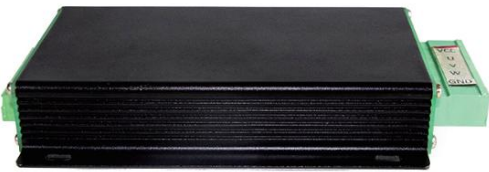
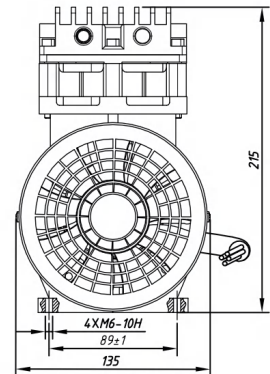
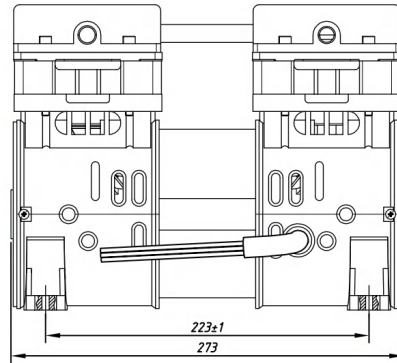
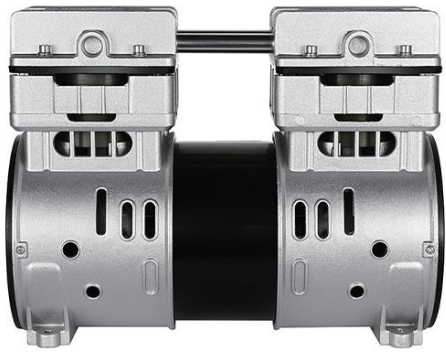

## HC750D2

### Technical Specification

<b>Model</b>	HC750D2
<b>Installation size</b>	89*223 mm(M6X4)
<b>Vacuum flow rate</b>	120 L/min @ -93 Kpa
	60 L/min @ -98 Kpa
<b>Dimension</b>	273×135×215 mm
<b>Voltage</b>	DC12V /24V /48V
<b>Power</b>	≤360W
<b>Rated speed</b>	≤1450rpm
<b>Noise</b>	≤60dB(A)
<b>Packing</b>	Carton case
<b>Net weight</b>	10.4kg
<b>Use environment</b>	-5℃-40℃
<b>Accessories</b>	1x Controller ,4x Rubber Feet ,1x air Filter

# DC Oil Free Vacuum Pump

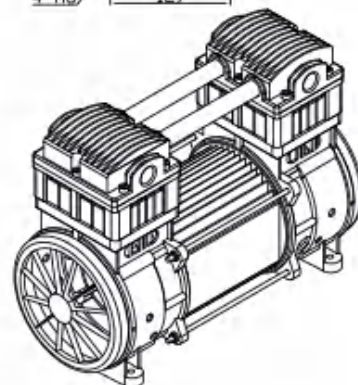
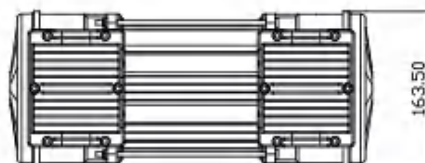
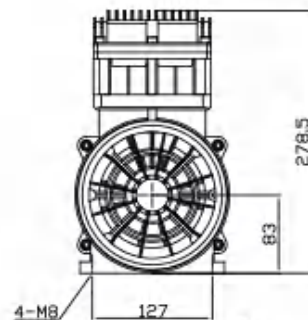
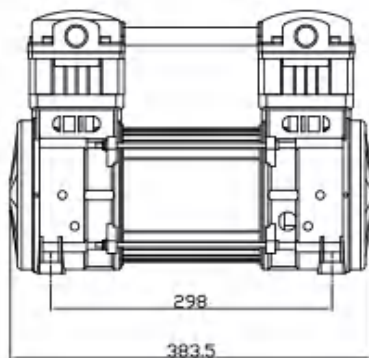
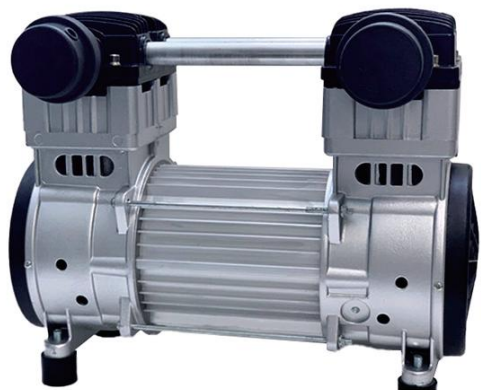

**HC1100D2**

## Technical Specification

Technical Specification	
<b>Model</b>	HC1100D2
<b>Installation size</b>	127*298 mm(M8X4)
<b>Vacuum flow rate</b>	200L/min @ -93Kpa
	100 L/min@-98Kpa
<b>Dimension</b>	383.5 *163.5*278.5mm
<b>Voltage</b>	DC12V /24V /48V
<b>Power</b>	≤600W
<b>Rated speed</b>	≤1450rpm
<b>Noise</b>	≤60dB(A)
<b>Packing</b>	Carton case
<b>Net weight</b>	12.6 kg
<b>Use environment</b>	-5℃-40℃
<b>Accessories</b>	1x Controller ,4x Rubber Feet ,1x air Filter



# DC Oil Free Vacuum Pump



**HC1500D2**

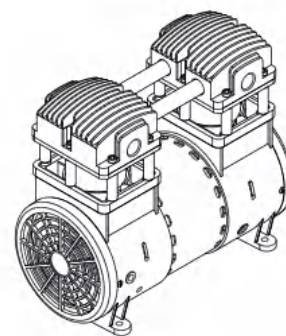
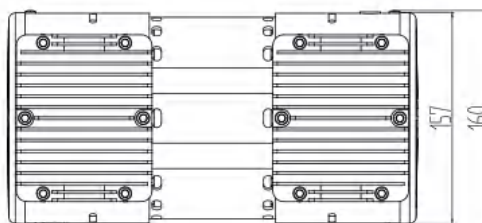
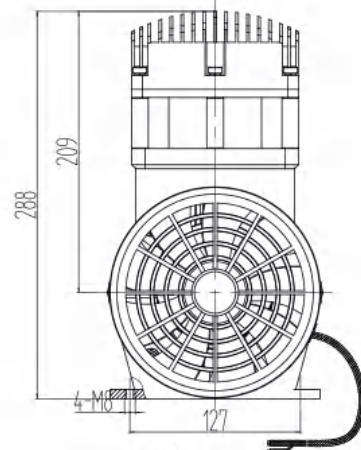
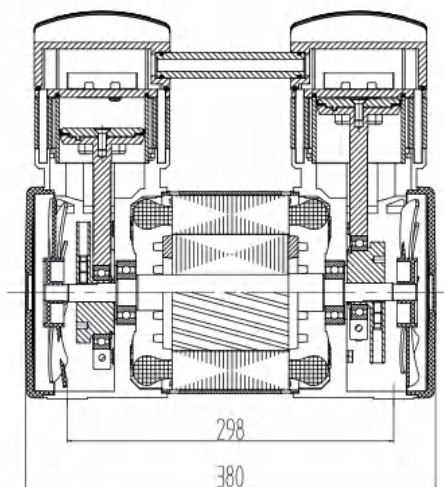

## Technical Specification

<b>Model</b>	HC1500D2
<b>Installation size</b>	127*298 mm(M8X4)
<b>Vacuum flow rate</b>	240 L/min@-93Kpa
	130 L/min@-98Kpa
<b>Dimension</b>	380 *160*288mm
<b>Voltage</b>	DC12V /24V /48V
<b>Power</b>	≤700W
<b>Rated speed</b>	≤1450rpm
<b>Noise</b>	≤60dB(A)
<b>Packing</b>	Carton case
<b>Net weight</b>	12.6 kg
<b>Use environment</b>	-5℃-40℃
<b>Accessories</b>	1x Controller ,4x Rubber Feet ,1x air Filter

# Vacuum Pump Complete Machine



**HC280A2X**

## Technical Specification

Technical Specification	
<b>Model</b>	HC280A2X
<b>Vacuum flow rate</b>	80L/min @-90Kpa
	40L/min @-97Kpa
<b>Dimension</b>	343*208*319mm
<b>Voltage</b>	220V/110V
<b>Power</b>	≤250W
<b>Rated speed</b>	1400rpm/1700rpm
<b>Noise</b>	≤50dB(A)
<b>Packing</b>	Carton case
<b>Net weight</b>	16kg
<b>Use environment</b>	-5℃-40℃
<b>Thermal Protector</b>	135±5℃

# Vacuum Pump Complete Machine

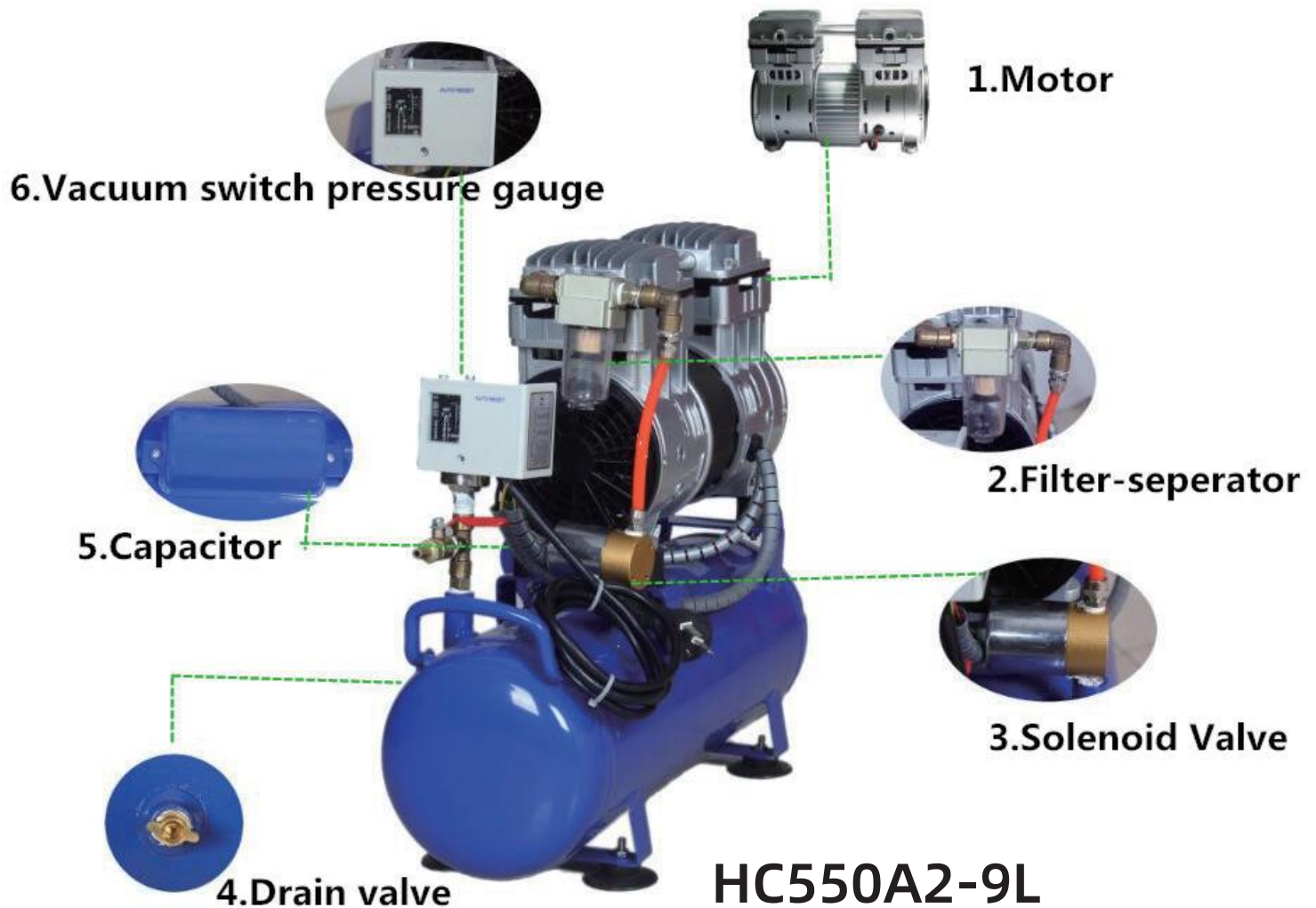

## Technical Specification

<b>Model</b>	HC550A2-9L
<b>Vacuum flow rate</b>	100L/min@-92Kpa
	50 L/min@-98Kpa
<b>Dimension</b>	520*180*460 mm
<b>Voltage</b>	220V/110V
<b>Power</b>	≤380W
<b>Rated speed</b>	1400rpm/1700rpm
<b>Noise</b>	≤50dB(A)
<b>Packing</b>	Carton case
<b>Net weight</b>	18kg
<b>Use environment</b>	-5℃-40℃
<b>Tank</b>	9 Liter



# Vacuum Pump Complete Machine



## Technical Specification

<b>Model</b>	HC750A2-24L
<b>Vacuum flow rate</b>	133 L/min@-92Kpa
	60 L/min@-98Kpa
<b>Dimension</b>	440*440*630 mm
<b>Voltage</b>	220V /110V
<b>Power</b>	≤500W
<b>Rated speed</b>	1400rpm/1700rpm
<b>Noise</b>	≤52dB(A)
<b>Packing</b>	Carton case
<b>Net weight</b>	30kg
<b>Use environment</b>	-5℃-40℃
<b>Tank</b>	24 Liter

## Accessories



Vacuum Filter



Solenoid valve



Cylinder



Capacitor



Capacitor Case



Drain valve



Piston Ring



Foot Pad



Sealing Ring



fan and cover



Pressure Switch



Silencer



switch box



Bearing



Handle

No	DESCRIPTION	Q'TY
1	SIDE COVER	2
2	LEFT FAN	2
3	ECC.&BEARING ASS'Y	2
4	CONNECTING ROD ASS'Y	2
5	CONNECT ROD	2
6	PISTON RING	2
7	FASTEN PLATE	2
8	CYLINDER	2
9	CYLINDER SEAL RING	2
10	VALVE PLATE ASSEMBLY	2
11	METAL CUSHION	2
12	LIMITING PLSTE	2
13	INTAKE VALVE	2
14	VALVE PLATE	2
15	EXHAUST VALVE	2
16	LIMITING PLSTE	2
17	SQUARE WASHER	2
18	O-RING GASKET-HEAD	2
19	CYLINDER COVER	2
20	"O" SEAL RING	4
21	CONNECT PIPE	2
22	REDUCE VIBRATION PILLARS	4
23	SILENCER	1
24	POWER LINE	1
25	CAPACITOR BOX	1

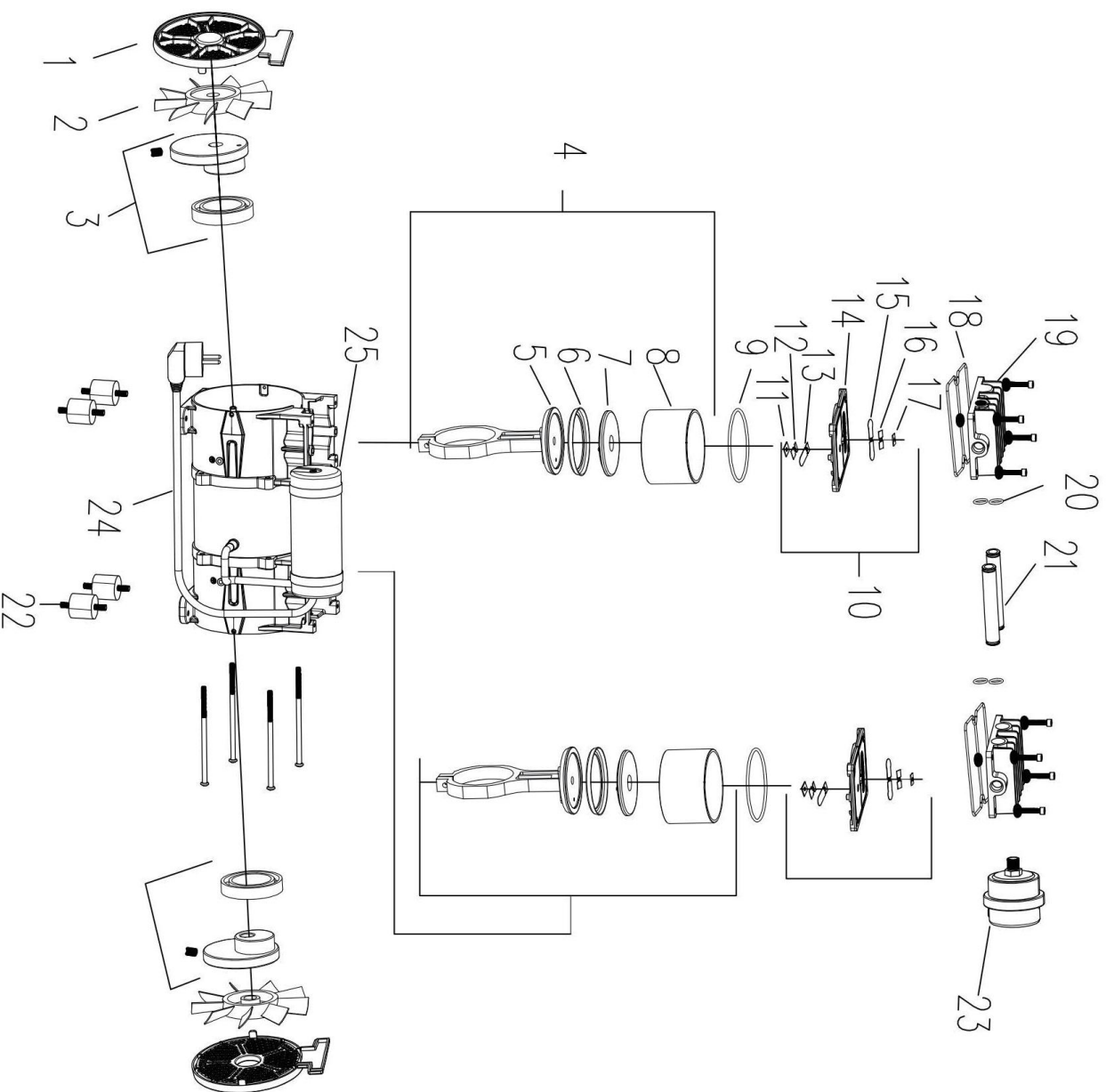



# **HCEM·鸿川医疗科技**

**HONGCHUAN MEDICAL TECHNOLOGY CO.,LTD**



**Web**



**Alibaba Web**



**1688 Web**

**Tell: 0579-85395979    Fax: 0579-85395960**

**Address : 1559 Guangshun Street,Xiaoshun Town, Jindong  
District,Jinhua City, Zhejiang Province , 321035**