

A photograph of a modern glass and steel building facade, viewed from a low angle looking up. The image is partially obscured by a blue curved overlay at the top and bottom.

# HCEM

**Zhejiang Hongchuan Medical Technology Co.,Ltd**

>>> **We make your life easiler and protect your health**

## HCO2A Disinfection Fogger Machine with double Nozzle



**HCEM**  
**DISINFECTION MACHINE**

- 01 SUPPORT ODM&OEM
- 02 TWO YEAR WARRANTY
- 03 20 YEARS OF PRODUCTION EXPERIENCE
- 04 FREE PARTS FOR REPLACE BY AIR SHIPPING

Health Life



**DISINFECTION FOGGER MACHINE**  
Stronger atomization  
Sterilization rate 99.99%

- Atomized particles directly cover diameter: 8 meter
- Atomized particles : 1-6um
- Atomization speed of the sterilizer  $\geq 60\text{ml/min}$

Health Life

# HC02A products parameter

MODEL	HC02A (Venturi atomization)
Product Name	Disinfectant Sprayer with touch screen panel
Net Dimension (L*W*H)	350*350*734.8 mm
Net Weight	25 kg
Power	320W
Atomization speed of the sterilizer	60ml/min
Diameter of area directly covered by atomization	≥8m
Atomized particles size	1-6μm
Atomization movement method	Disperse in the air to form Brownian motion, and quickly fill the entire room
Liquid tank capacity	3.7 liter

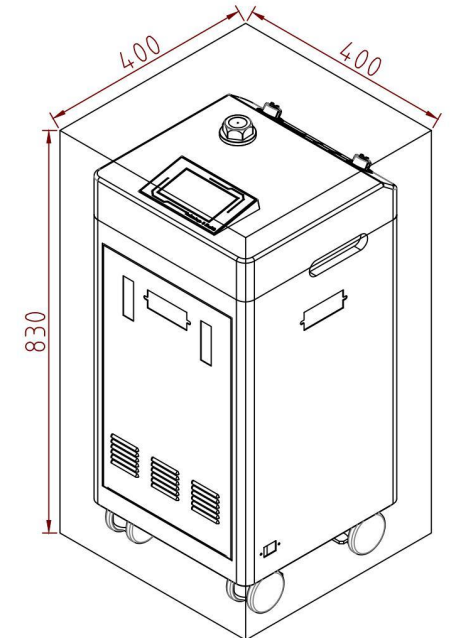
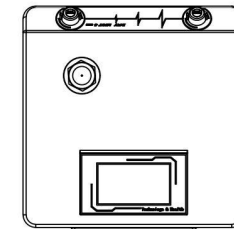
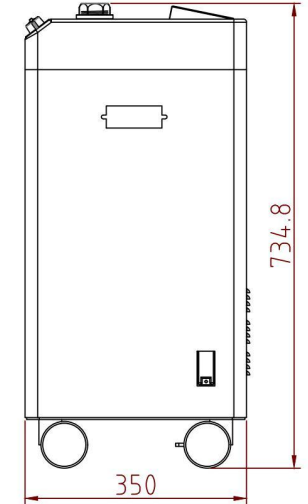
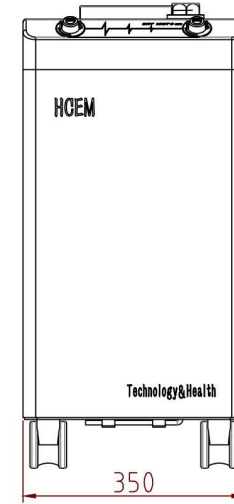

## HC02A products application



# HC02A Disinfection Fogger Machine with double Nozzle

## BUTTON FUNCTION

Stainless steel box with spray treatment, more corrosion resistant



 FLUID LEVEL	 060 min	 TEMP
Disinfectant consumption can see clearly	Can set time ,save more energy and labor cost	Higher than working temperature, will stop automatically
 PRESSURE	START	 HUMIDITY
Using frequency conversion brushless motor to ensure working state always best	After start the machine have 9 seconds delay , more safe for operator	Can set the humidity , prevent disinfectant corrode equipments

# HC02A Disinfection Fogger Machine with double Nozzle

## SHOW DETAILS



- All stainless steel shell spray treatment, more corrosion resistant.

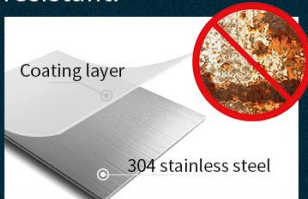

- More efficient nozzle with patent , keep the particle size more smaller , and more efficient to play the disinfectant effect.

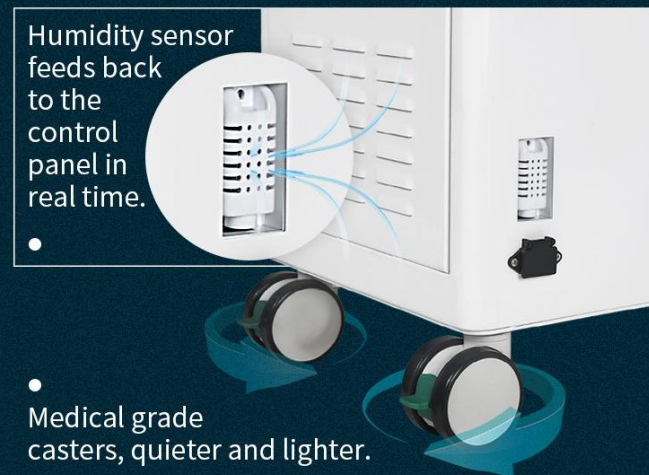

Humidity sensor feeds back to the control panel in real time.

- Medical grade casters, quieter and lighter.



- The built-in high-precision liquid filter to protect the nozzle well , manual drainage system allows the remaining disinfectant to be discharged quickly , which prevent crystallization and oxidation in case of affect the anti-virus effect.

## HC01A Disinfection Fogger Machine with Single Nozzle



# HC01A products parameter

MODEL	HC01A (Venturi atomization)
Product Name	Disinfectant Sprayer with touch screen panel
Net Dimension (L*W*H)	360*248*598 mm
Net Weight	15 kg
Power	243W
Use pressure	260Kpa - 300Kpa
Diameter of area directly covered by atomization	≥8m
Atomized particles size	1-6μm
Atomization movement method	Disperse in the air to form Brownian motion, and quickly fill the entire room
Liquid tank capacity	2 liter

## Application





# HC01A Exploded figure

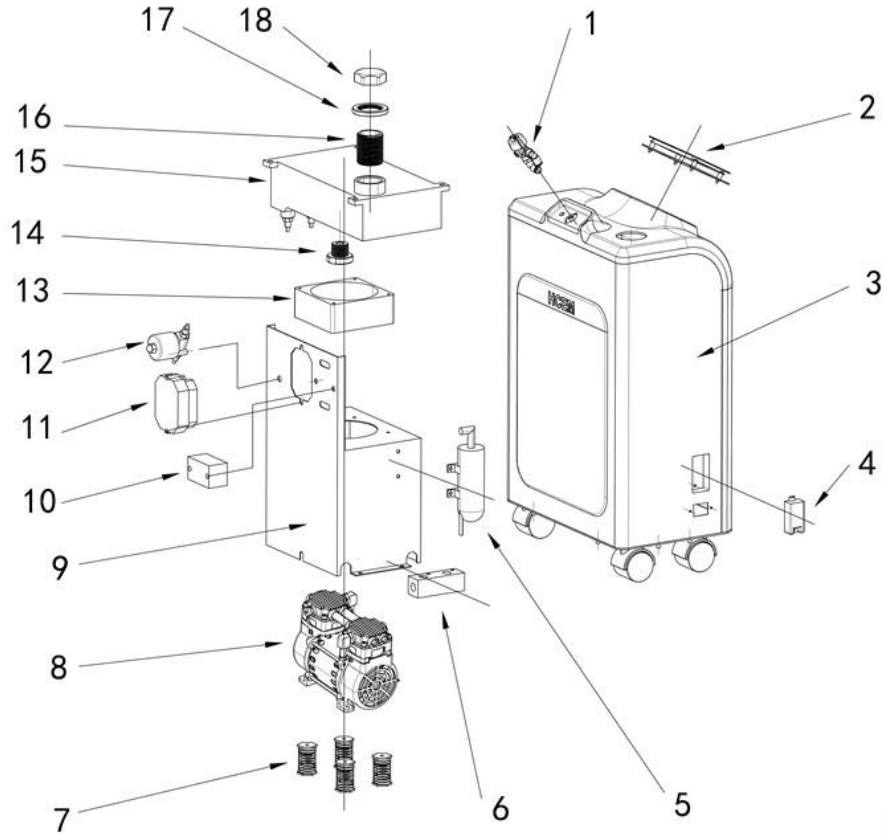

No	Parts name	Quantity
1	Nozzle components	1
2	Control panel	1
3	External box	1
4	Humidity sensor	1
5	Muffler	1
6	Tee fitting	1
7	Vibration damping springs	4
8	100W motor	1
9	Inner box	1
10	3-3 connecting rows	1
11	Motor driver	1
12	Solenoid valve for water discharge	1
13	Fan	1
14	Water level gauge street	1
15	Liquid tank	1
16	Threaded pipe for water filler	1
17	Water fill port seal	1
18	Water tank lid	1
19	"O" seal ring	8

# HC01A Disinfection Fogger Machine with Single Nozzle

## BUTTON FUNCTION

Stainless steel box with spray treatment, more corrosion resistant



Metric	Value	Status	Description
FLUID LEVEL	0 %	normal	Disinfectant consumption can see clearly
TEMP	25 °C	normal	Higher than working temperature, will stop automatically
PRESSURE	360 Kpa	normal	Using frequency conversion brushless motor to ensure working state always best
Time	060 min		Can set time, save more energy and labor cost
HUMIDITY	88.8 %	normal	Can set the humidity, prevent disinfectant corrode equipments
START	START		After start the machine have 9 seconds delay, more safe for operator

# HC01A Disinfection Fogger Machine with Single Nozzle

## SHOW DETAILS



- All stainless steel shell spray treatment, more corrosion resistant.

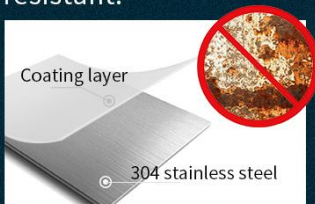

- More efficient nozzle with patentent , keep the particle size more smaller , and more efficient to play the disinfectant effect.



Humidity sensor feeds back to the control panel in real time.

- 

- Medical grade casters, quieter and lighter.

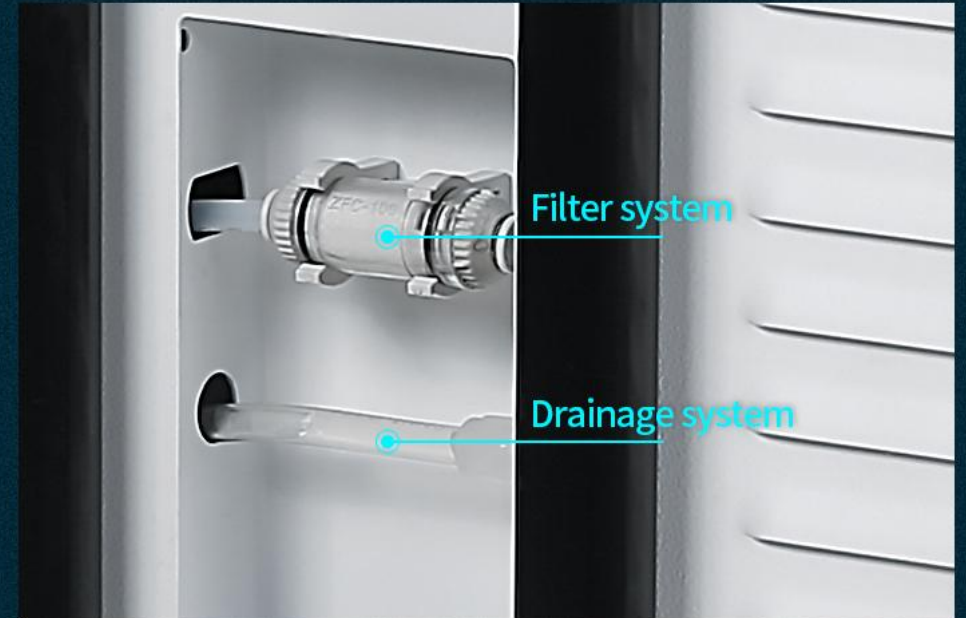
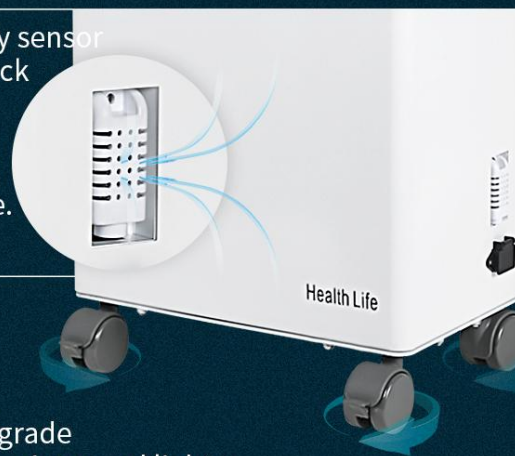

- The built-in high-precision liquid filter to protect the nozzle well , manual drainage system allows the remaining disinfectant to be discharged quickly , which prevent crystallization and oxidation in case of affect the anti-virus effect.

# HC01A Disinfection Fogger Machine with Single Nozzle

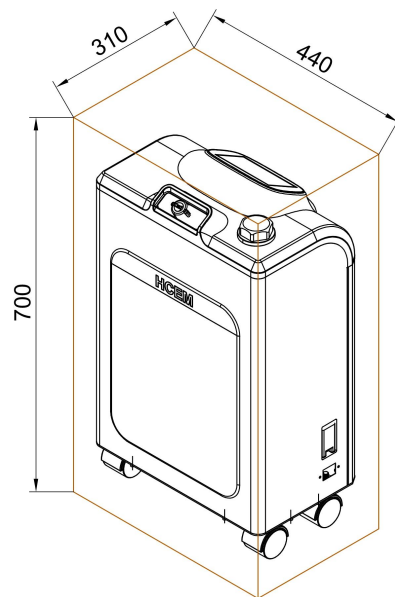
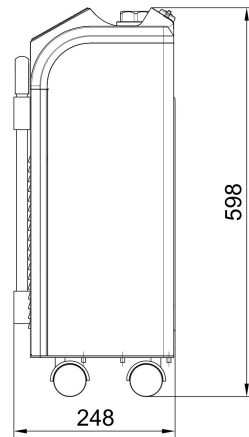
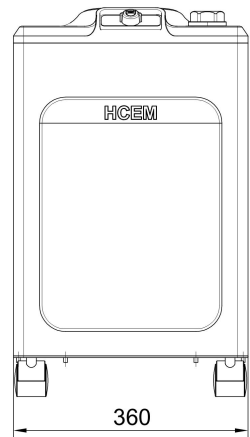

## APPLICABLE TO THE PRODUCT



HYDROGEN PEROXIDE SOLUTION



HYPOCHLOROUS ACID SOLUTION



HYDROGEN PEROXIDE WITH SILVER BASED



NEUTRAL HYPOCHLOROUS ACID



PH 7.00, PEROXYACETIC ACID



HYDROGEN PEROXIDE WITH WATER



more

Compatible with all disinfectants in the market

# HC10A Dry mist hydrogen peroxide-- AI Precison Autonomous Sanitizing Robot

Reduce more labor cost



50° swing spray from left to right,  
Covers more evenly.  
Spray diameter > 5 meters,  
Higher disinfection efficiency

Autonomous planning route  
Automatically recognize obstacles,  
It can be linked with elevator control and  
door control debugging.

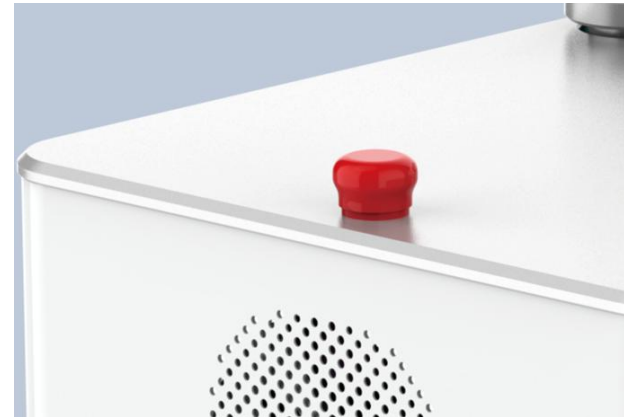

Emergency stop button, more safe



Increase the plasma module, through  
the plasma disinfection to achieve rapid  
inhibition of virus reproduction.

MODEL	HC10A
Product Name	Dry mist hydrogen peroxide-- AI Precision Autonomous Sanitizing Robot
Dimension ( LxWxH)	550 x 365 *770 MM
Net weight	75 KG
Voltage	DC24V
Power	500W
Maximum operating speed	1m/s , Can pass 1.4cm right-angle steps and a gap of 65mm width
Battery power	lithium battery ,Single battery life 4~6 hours ,DC24V 90Ah ; Standard charger ( can chose automatic charging) , automatic charging pile 6~8 hours
Communication method	Wifi +4G/5G
Particle size	Sanitizing fog particle size is 1-10 microns to avoid residue on the floor, furniture, or your equipment
Navigation method	Laser navigation + visual navigation + avoid obstacles autonomously
Robot control	iPad control , Multi-level access control
Disinfectant area	$\leq 2000 \text{ m}^3$
Disinfection spray	Disinfectant :7.5% hydrogen peroxide ; Capacity: 10 liter ; Particle size:1~10 $\mu\text{m}$ ; Spray diameter: 5m ; Spray speed : 58ml/min ; Spray volume: 5mL/m <sup>3</sup> ; working time : 45 min ; Sterilization time : After spraying, leave it for 20 minutes for continuous disinfection. Ventilation time : 15~30 min

## Application



# HC01D Portable atomization disinfection machine

Small space, quick disinfection

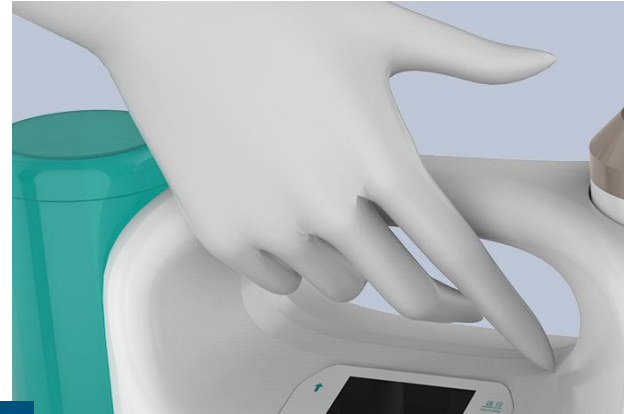
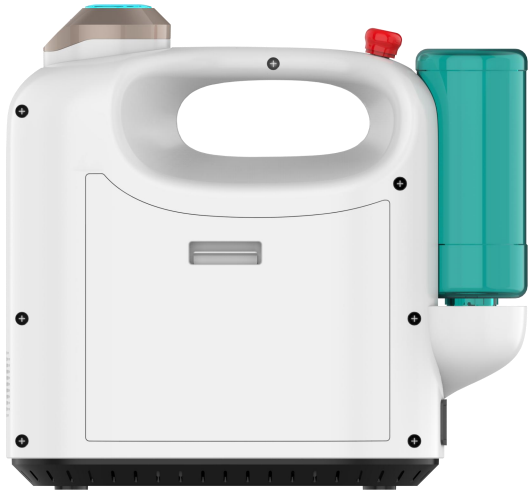

Ergonomic design handle,  
It is convenient for operators to carry



Quick disassembly bottle design,  
Convenient to replace the disinfectant,  
and can be dumped to detect

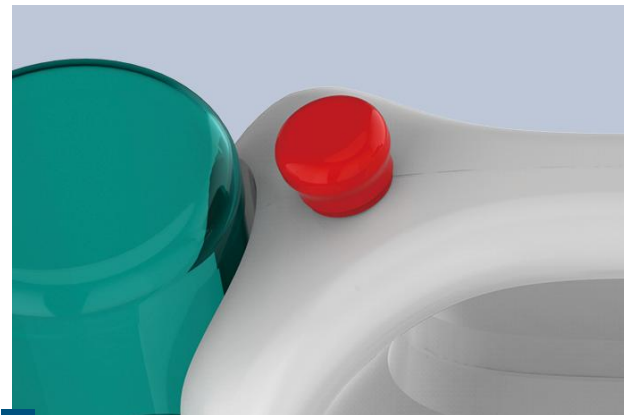

Emergency stop button,  
Convenient to use in emergency  
treatment



Touch button control,  
The display screen displays various  
disinfection information

PRODUCTS SPECIFICATION	
Weight	9kg
Dimension	418x192x390mm
Atomized particle size	Average 1-6 $\mu$ m
*Atomization speed of the sterilizer	$\geq$ 30ml/min
*Atomization outlet rotation	The atomization outlet reciprocates in the range of 270°, which promotes the rapid and uniform filling of the dry mist in the disinfection space.
*Atomized particles directly cover the diameter	$>$ 8m
*Maximum coverage area	100m <sup>2</sup>
Working temperature and humidity	-10°C~50°C, 0~80%RH
Power supply	AC220V, 50Hz
*Dedicated energy station	Available for 2 hours of continuous work of the sterilizer
disinfectant	7.5% concentration hydrogen peroxide solution
Disinfectant installation method	The 1 liter disinfectant bottle is carded, and the solution bottle can be directly replaced.
Material	ABS Flame-retardant shell, corrosion-resistant
Control & system SPECIFICATION	
show	2.8 inch display
Control	Touch button
Status light	Status light display on the top of the machine
Anti-dumping	When the disinfection machine is tilted more than 30°, it will automatically stop disinfection
Prevent dry burn	Automatically stop disinfection when the disinfectant is consumed
remote control	Can be controlled by wireless remote control
Phone control	Can be controlled through the small program APP
*Networking	Can be connected to the cloud platform via 4G
operate	Visualized and convenient operation, simple and convenient, the system automatically calculates the spray time according to the setting space. It will stop automatically after disinfection.
Wait for disinfection	After starting the disinfection, there is a waiting time of 30 seconds for the personnel to withdraw from the disinfection site.
Sterilization capacity and application scenarios	
Sterilization level	Up to Ig6 kill rate
Sterilization rate	Staphylococcus albicans killing rate $\geq$ 99.99% Air natural bacteria killing rate $\geq$ 93.77%
Scope of application	Disinfection of ambulances, buses, nursing homes, pet shops, toilets, high-speed toll booths and small spaces

## Application

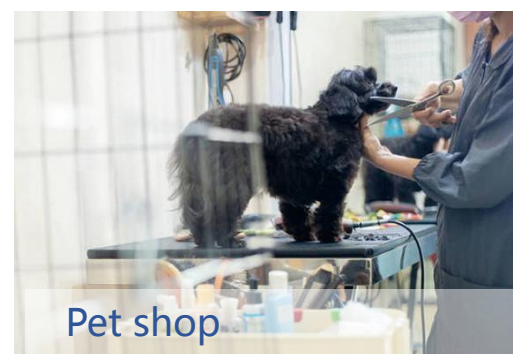



## HC02D Wall-mounted disinfection machine

Rose gold



Cyan-blue



Lemon yellow



White



According to different application areas,  
different colors can be selected



Magnetic flip cover, easy to open and  
add liquid.

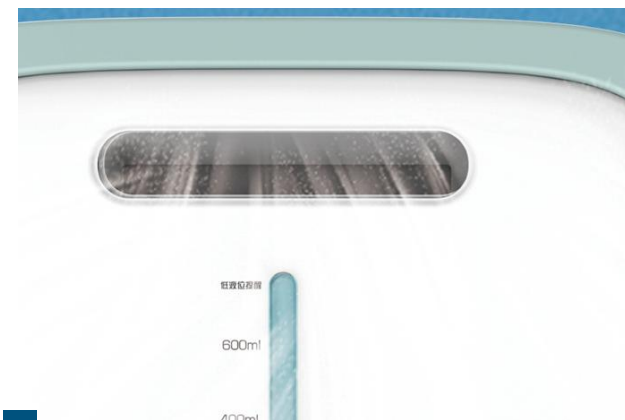

5L/H large amount of fog,  
Can achieve disinfection effect in large  
space in a short time.



Status indicator design, the machine  
status such as liquid filling reminder and  
malfunction can be clearly seen



High definition display,  
Set disinfection information and start  
disinfection with button

MODEL	HC02D
Capacity	6L
Spray speed	5L/H
Spray distance	>5M
Atomized particles	5 $\mu$ m
Disinfectant	50-100mg/ LHypochlorous acid
Killing efficiency	Disinfect the air at the simulated site with an extermination rate >99.9% Disinfect the surface of the simulated site with an extermination rate >99.9%
Power supply	AC 220V/50HZ
Configuration	Poisoning parameters can be configured locally or remotely, one-key start disinfection data can be checked
Working temperature	5°C-40°C
Weight	8.4kg
Dimensions size	454*429*231mm
Type of sterilization	Atomization kills Staphylococcus albicans, natural air bacteria, Escherichia coli, Staphylococcus aureus, Bacillus subtilis black variants, etc.
Deodorizing effect	Hypochlorous acid can effectively remove the odor generated by chemicals such as sulfur dioxide, ammonia, propionic acid, etc., and can be used for toilet deodorization, deodorization of livestock and poultry breeding, deodorization of garbage dumps, deodorization of pet hospitals, etc.

## Application



Clinic



CT room



Hospital room



Public toilet

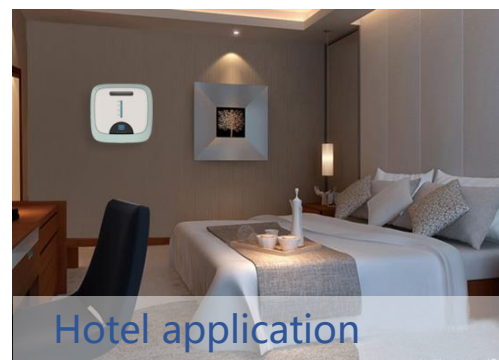

Hotel application



Meeting Room

# HC03D New Nano Spray Gun

MODEL	HC03D
Product Name	New Nano Disinfection Spray Gun
Net Dimension (L*W*H)	205*65*205mm
Net Weight	0.35KG
Power	25W
Operating Voltage	DC12V
Jetting Distance	1M-2.5M
Charging Voltage	DC5V 1.5A
Battery capacity	2600MA
Power Supply Mode	External 18650 The lithium battery
Volume Of Liquid Tank	500ML
Each Box	16 PCS
Box Size/16 PCS	450*420*365mm



## USE OF THE PRODUCT

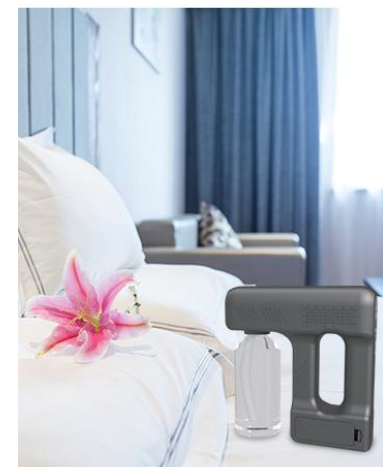

**THE HOTEL USE**



**THE DISINFECTION THAT  
OCCUPY THE HOME**



**CAR IN ADDITION TO MITES**



**KTV DISINFECTION**

## SELLING POINTS OF PRODUCTS



### METAL NOZZLE

LONG SERVICE LIFE,  
NOT EASY TO PLUG

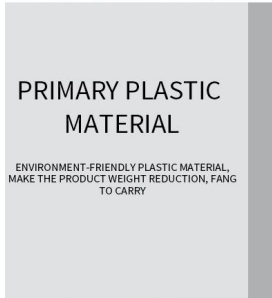

### PRIMARY PLASTIC MATERIAL

ENVIRONMENT-FRIENDLY PLASTIC MATERIAL,  
MAKE THE PRODUCT WEIGHT REDUCTION, FANG  
TO CARRY



### CONSTANT PRESSURE SPRAY

EQUILIBRIUM SPRAY PRINCIPLE MAKES  
THE PRESSURE STABILITY  
EXTERNAL 18650 LITHIUM BATTERY

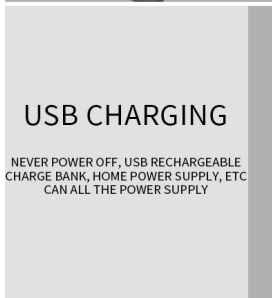

### USB CHARGING

NEVER POWER OFF, USB RECHARGEABLE  
CHARGE BANK, HOME POWER SUPPLY, ETC  
CAN ALL THE POWER SUPPLY



### THE STANDARD 500 ML LARGE CAPACITY LIQUID BIN

IT CAN BE MATCHED WITH 500-2000ML  
COKE BOTTLES

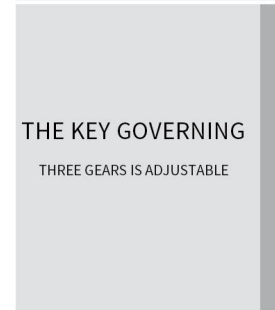

### THE KEY GOVERNING

THREE GEARS IS ADJUSTABLE



### UNIVERSAL MICRO USB CHARGING PORT

EXTERNAL 18650 LITHIUM BATTERY

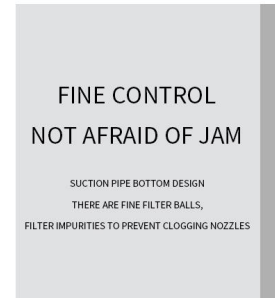

### FINE CONTROL NOT AFRAID OF JAM

SUCTION PIPE BOTTOM DESIGN  
THERE ARE FINE FILTER BALLS,  
FILTER IMPURITIES TO PREVENT CLOGGING NOZZLES



# PRODUCT FEATURES



**01**

Kill bacteria and mites

**02**

Disinfection sterilization

**03**

Humidifying function

**04**

Remove the peculiar smell



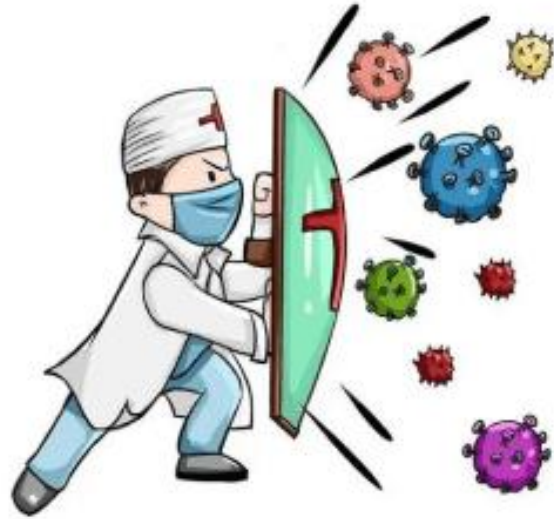

## WHY CHOOSE US?



### NANO SPRAY GUN

- ✓ Nano spray technology
- ✓ Constant pressure controlled spray
- ✓ Charging with USB interface
- ✓ Removable and non-clogging
- ✓ Metal sprinkler device
- ✓ Support lithium battery removal



### ORDINARY SPRAY GUN

- ✗ Squeeze spray gun
- ✗ The more the spray, the less the pressure
- ✗ Manual press spray
- ✗ Easy to clog when disassembly
- ✗ Shows for plastic products

# 感谢您的观看

Thank You For Watching

**SUPPORT US! JOIN US!**  
**WE ARE SERVICE FOR YOU 24 HOURS!**

**Contact :**

Lisa Wang - sales manager

Zhejiang Hongchuan Medical Technology Co.,Ltd

Phone : +86 0579 8539 5979 | WhatsApp/ Mobile:(+0086) 15925994563

Address : No.26,Weiya Road ,Shangxi ,Yiwu ,jinhua , Zhejiang,China,322006

Web: [www.hcem.cn](http://www.hcem.cn)

