



HCEM · 鸿川医疗科技

HONGCHUAN MEDICAL TECHNOLOGY CO.,LTD



DC Air Compressor



Company Introduction:

Zhejiang Hongchuan Medical Technology Co.,Ltd was first established in 2010 , which is a large-scale enterprise group ,we are specializing in R&D and manufacturing various kinds of air compressor , vacuum pump and automatic disinfection machine .

Our products mainly serve industries such as medical equipment, dental equipment ,robotic arms, automation equipment, beauty equipment, packaging equipment, new energy vehicles and pond aeration systems etc .

Dedicated to strict quality control and thoughtful customer service, our experienced engineers are always available to discuss your requirements and ensure full customer satisfaction. From the structural design , appearance design and mold development are all done by our own R&D team .

For all products ,we all have 2-5 years quality warranty .We have a very rigid inspection process , and all goods need 3 times QC inspection, so we can make sure good quality.

Our company don't have complicated application process, so if you have any requirement, we can react much faster without waiting for application result for a long time.

Our products are sold well in all cities and provinces around China, and also exported to USA , Germany ,UK , Italy ,Spain ,New Zealand, Australia , Russia , Indonesia and South Korea etc.

We are welcome the OEM and ODM orders. Whether selecting a current product from our catalog or seeking engineering assistance for your application, you can talk to our customer service center about your sourcing requirements.

Adhering to the business principle of mutual benefits, we have had a reliable reputation among our customers because of our professional services, quality products and competitive prices.

If you have questions or thoughts , please contact us freely. Most of our customers have 30-50% increase of business every year, we hope we can also help your business grow, and let's grow together.

PROFESSIONAL MANUFACTURER FOR ODM SERVICE



01 HIGH EFFICIENCY & INNOVATE

Dedicated to strict quality control and thoughtful customer service, our experienced engineers are always available to discuss your requirements and ensure full customer satisfaction. From the structural design, appearance design and mold development are all done by our own R&D team.

02 STRENGTH SOURCE FACTORY

Starting from die-casting of raw materials, high-speed punch of motor, hardware processing, automatic embedding of motor, as well as automatic assembly line of products, all core technologies are strictly in accordance with the standardized operation, testing, and production, the annual capacity of 800,000 sets of air compressors & suction vacuum pumps manufacturer.

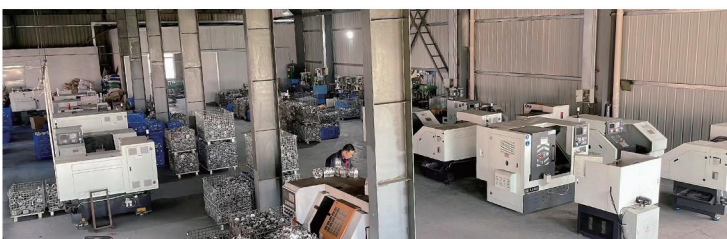

STRICT TESTING PROCESS TO GUARANTEE THE HIGH QUALITY

For us, we consider quality as most important factor, and employ QC with more than 5 years of experience, and very rigid to quality control.

Every compressor have to pass 3 times check, and our inspection standard is much more rigid,so we can make sure good quality.

Every machine parameters have the test records , we will keep these test records to our quality traceability system about 5 years.The compressor label shows the S/N all are matched with test record



Authorization

Certificates



Utility Patents



Application



Solar aerator



Oxygen machine



Electric Vehicle

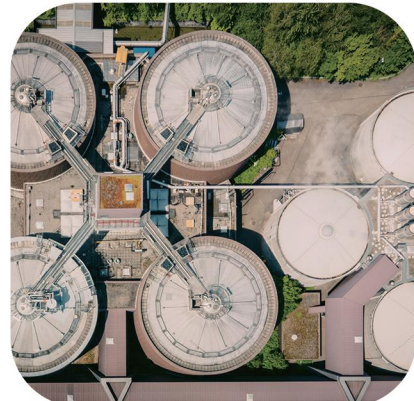

Sewage treatment



Hydrogen compressor



Industrial compressor

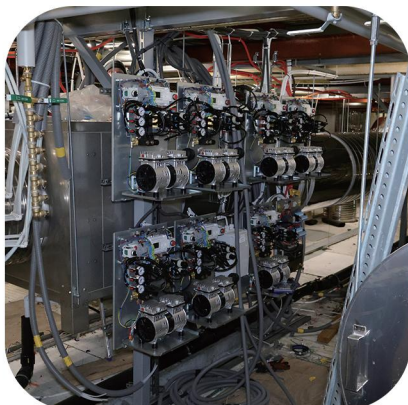

Biology system



Laboratory and medical

DC Oil Free Air Compressor

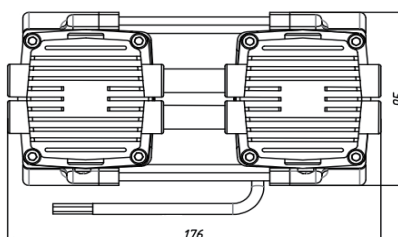
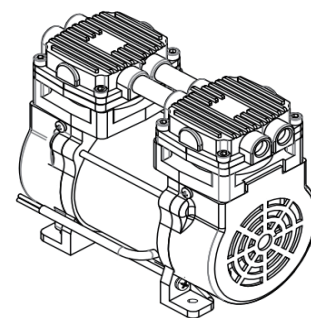
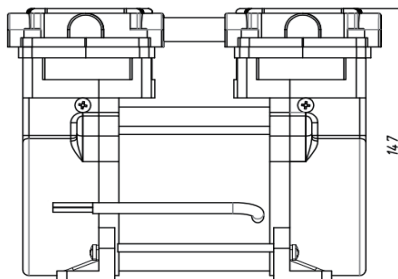
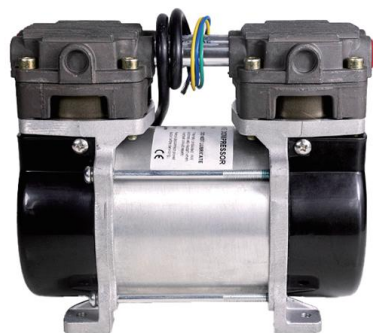

HC100D

Technical Specification

Model	HC100D
Air flow rate	50 L/min@0 bar
	36 L/min@2 bar
	22 L/min@4 bar
	9 L/min@7 bar
Dimension	176*95*147 mm
Installation size	70*114 mm(4xM6)
Voltage	DC12V /24V /48V
Power	≤230W
Rated speed	1450rpm
Noise	≤55dB(A)
Packing	2 pcs / carton case
Net weight	3.2 kg
Use environment	-5°C-40°C
Accessories	1x Controller ,4x Rubber Feet ,1x Air Filter

HC100D air flow rate curve

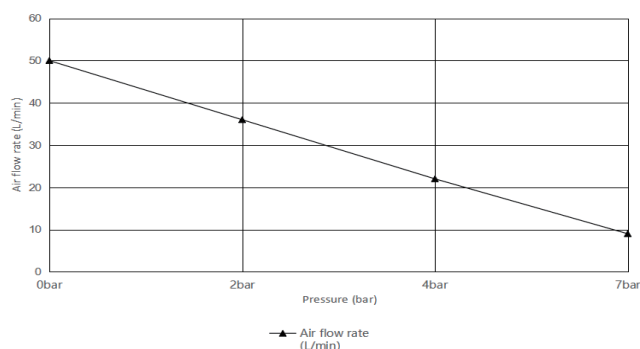

Feature:	Application:
Oil free operation (maintenance free)	Manual DIY
Brushless Motor with longer life	Oxygen concentrator
Lower vibration & noise	Electric vehicles
Imported consumable parts	Solar Pond Aerator
Lighter weight & smaller volume than AC	Field mast
24 hour continuous & stable output	Biology system

DC Oil Free Air Compressor

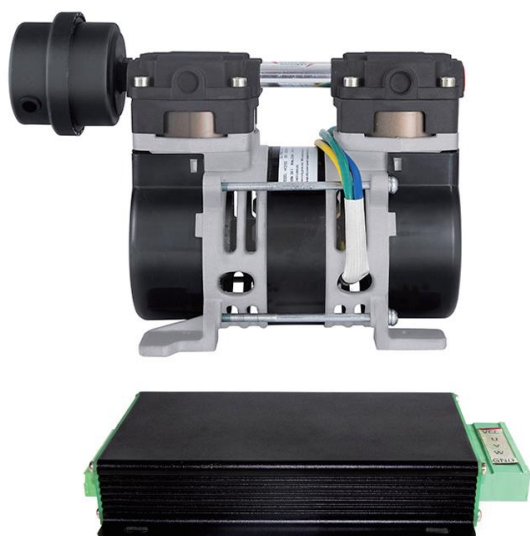

HC210D

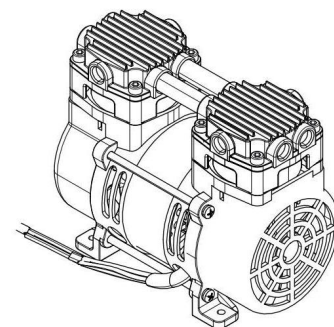
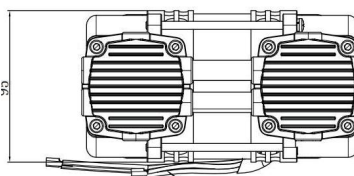
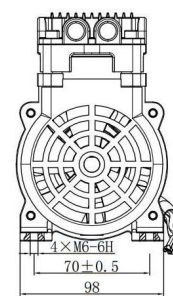
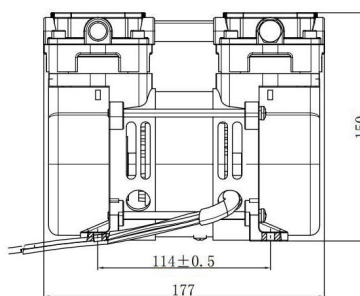

Technical Specification

Model	HC210D
Air flow rate	62 L/min@0 bar
	50 L/min@2 bar
	35 L/min@4 bar
	17 L/min@6 bar
	11 L/min@7 bar
Dimension	177*98*150 mm
Installation size	70*114 mm(4xM6)
Voltage	DC12V /24V /48V
Power	≤210W
Rated speed	1450rpm
Noise	≤55dB(A)
Packing	2 pcs / carton case
Net weight	3 kg
Use environment	-5°C-40°C
Accessories	1x Controller ,4x Rubber Feet ,1x Air Filter

HC210D air flow rate curve

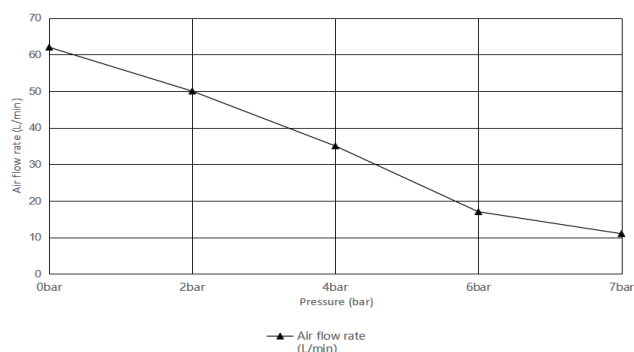

Feature:	Application:
Oil free operation (maintenance free)	Manual DIY
Brushless Motor with longer life	Oxygen concentrator
Lower vibration & noise	Electric vehicles
Imported consumable parts	Solar Pond Aerator
Lighter weight & smaller volume than AC	Field mast
24 hour continuous & stable output	Biology system

DC Oil Free Air Compressor

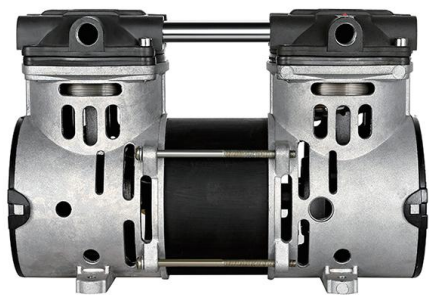

HC280D

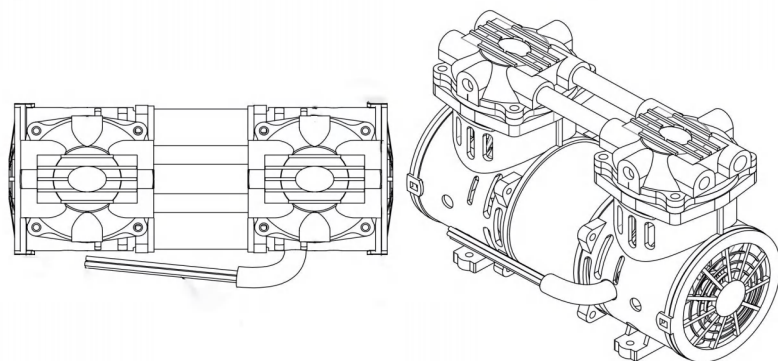
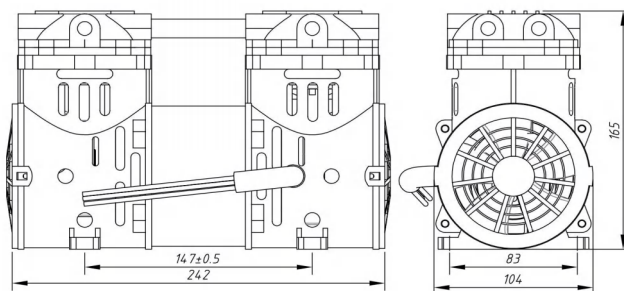

Technical Specification

Technical Specification	
Model	HC280D
Air flow rate	75L/min@0 bar
	50L/min@2 bar
	30L/min@4 bar
	21L/min@6 bar
	15L/min@7 bar
Dimension	242*104*165 mm
Installation size	83*147 mm(4xM6)
Voltage	DC12V /24V /48V
Power	≤330W
Rated speed	1450rpm
Noise	≤58dB(A)
Packing	2 pcs / carton case
Net weight	6.0 kg
Use environment	-5℃-40℃
Accessories	1x Controller ,4x Rubber Feet ,1x Air Filter

HC280D air flow rate curve

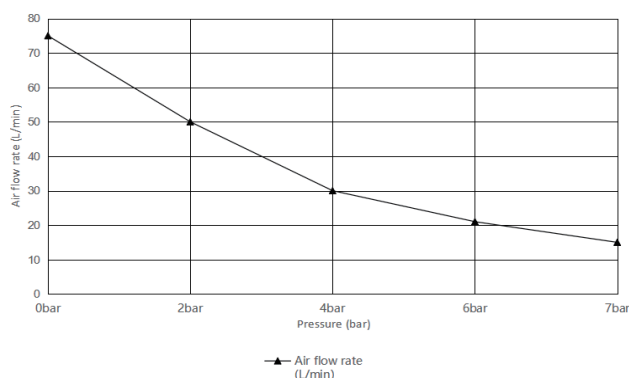

Feature:	Application:
Oil free operation (maintenance free)	Manual DIY
Brushless Motor with longer life	Oxygen concentrator
Lower vibration & noise	Electric vehicles
Imported consumable parts	Solar Pond Aerator
Lighter weight & smaller volume than AC	Field mast
24 hour continuous & stable output	Biology system

DC Oil Free Air Compressor



HC550D

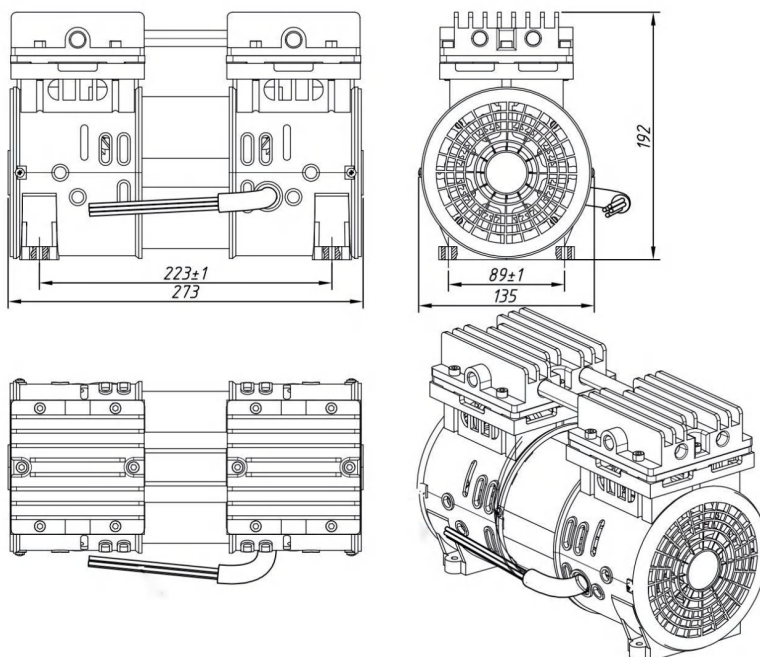

Technical Specification

Model	HC550D
Air flow rate	100L/min@0 bar
	75 L/min@2 bar
	60 L/min@4 bar
	46 L/min@6 bar
	36 L/min@8 bar
Dimension	273*135*192 mm
Installation size	89*223 mm(4xM6)
Voltage	DC12V /24V /48V
Power	≤550W
Rated speed	1450rpm
Noise	≤65dB(A)
Packing	1 pcs / carton case
Net weight	9.95 kg
Use environment	-5℃ -40℃
Accessories	1x Controller ,4x Rubber Feet ,1x Air Filter

HC550D air flow rate curve

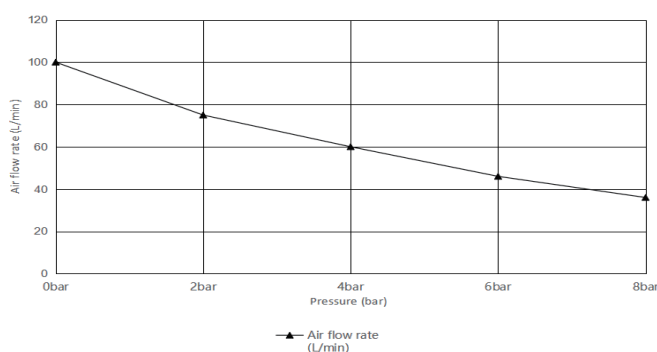

Feature:	Application:
Oil free operation (maintenance free)	Manual DIY
Brushless Motor with longer life	Oxygen concentrator
Lower vibration & noise	Electric vehicles
Imported consumable parts	Solar Pond Aerator
Lighter weight & smaller volume than AC	Field mast
24 hour continuous & stable output	Biology system

DC Oil Free Air Compressor

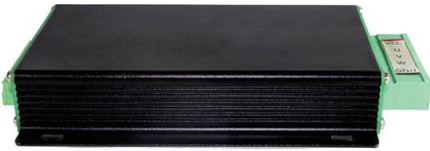
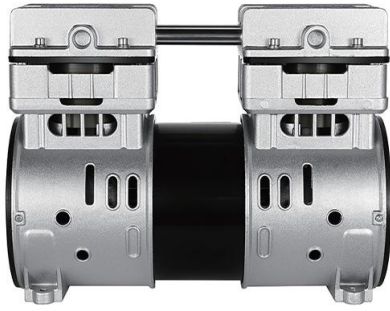

HC750D

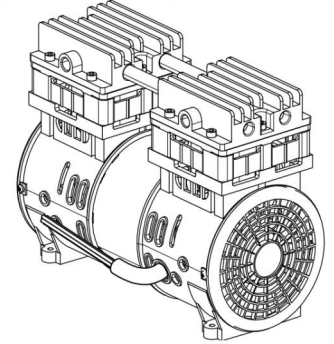
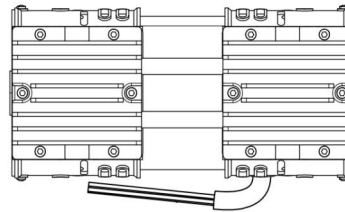
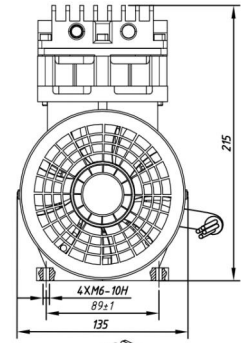
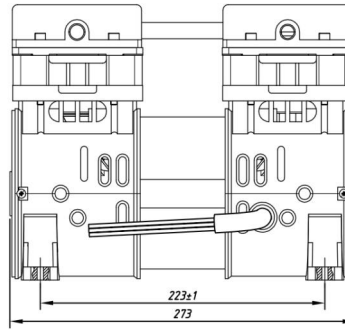

Technical Specification

Technical Specification	
Model	HC750D
Air flow rate	133L/min@0 bar
	116L/min@2 bar
	90L/min@4 bar
	73L/min@6 bar
	60L/min@8 bar
Dimension	273*135*215 mm
Installation size	89*223 mm(4xM6)
Voltage	DC12V /24V /48V
Power	≤750W
Rated speed	1450rpm
Noise	≤67dB(A)
Packing	1 pcs / carton case
Net weight	10.4 kg
Use environment	-5°C -40°C
Accessories	1x Controller ,4x Rubber Feet ,1x Air Filter

HC750D air flow rate curve

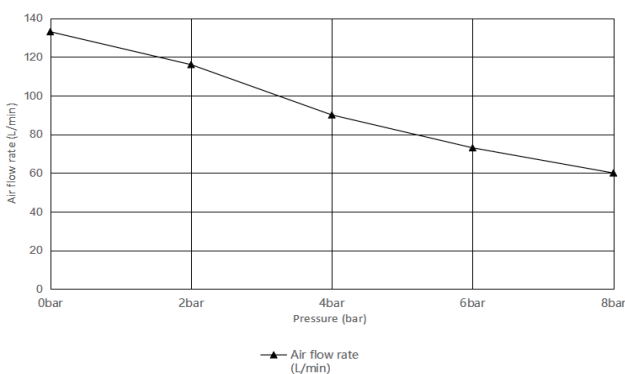

Feature:	Application:
Oil free operation (maintenance free)	Manual DIY
Brushless Motor with longer life	Oxygen concentrator
Lower vibration & noise	Electric vehicles
Imported consumable parts	Solar Pond Aerator
Lighter weight & smaller volume than AC	Field mast
24 hour continuous & stable output	Biology system

DC Oil Free Air Compressor



HC1100D

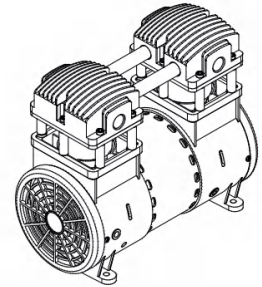
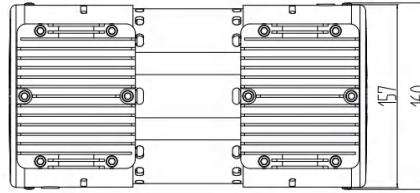
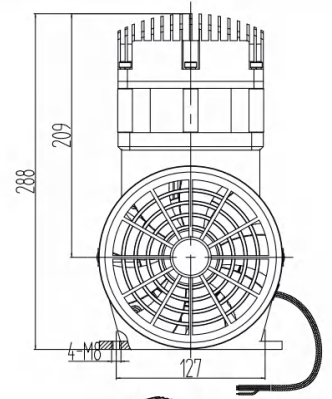
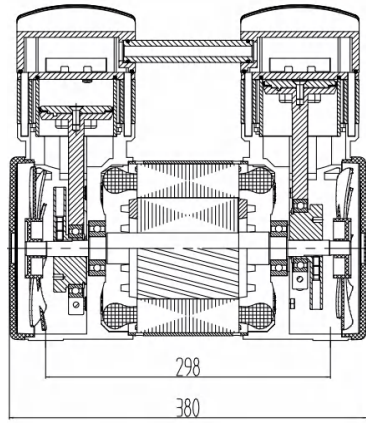

Technical Specification	
Model	HC1100D
Air flow rate	200 L/min@0 bar
	170 L/min @2 bar
	136 L/min @4 bar
	120 L/min @6 bar
	100 L/min@8 bar
Dimension	380 *160*288 mm
Installation size	127*298 mm(4xM8)
Voltage	DC12V/24V/48V/110V/144V
Power	≤1100W
Rated speed	1450rpm
Noise	≤70dB(A)
Packing	1 pcs / carton case
Net weight	12.6 kg
Use environment	-5℃-40℃
Accessories	1x Controller ,4x Rubber Feet ,1x Air Filter

HC1100D air flow rate curve

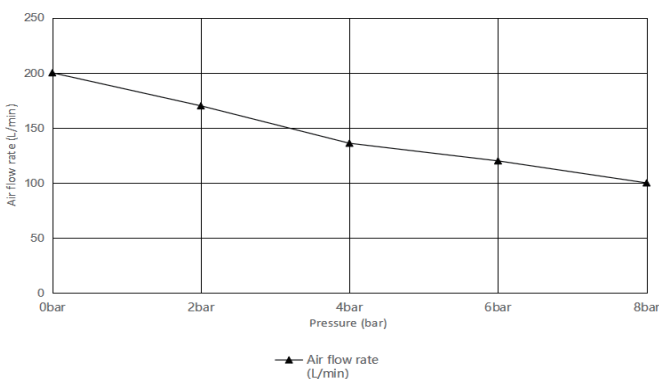

Feature:	Application:
Oil free operation (maintenance free)	Manual DIY
Brushless Motor with longer life	Oxygen concentrator
Lower vibration & noise	Electric vehicles
Imported consumable parts	Solar Pond Aerator
Lighter weight & smaller volume than AC	Field mast
24 hour continuous & stable output	Biology system

DC Oil Free Air Compressor



HC1500D

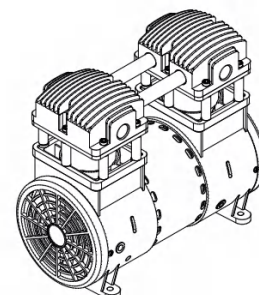
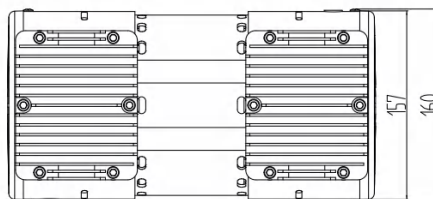
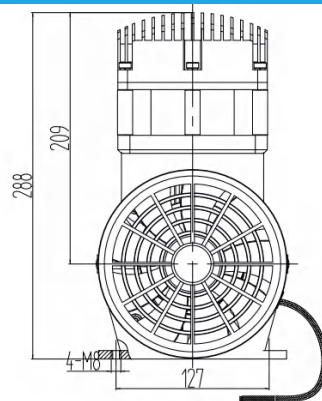
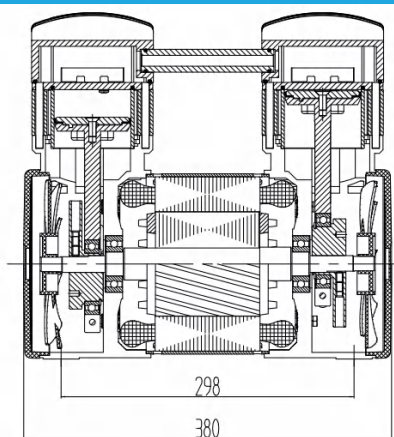

Technical Specification

Model	HC1500D
Air flow rate	250 L/min@0 bar
	210 L/min @2 bar
	180 L/min @4 bar
	160 L/min @6 bar
	140 L/min @8 bar
Dimension	380*160*288 mm
Installation size	127*298 mm(4xM8)
Voltage	DC12V/24V/48V/110V/144V
Power	≤1500W
Rated speed	1450rpm
Noise	≤70dB(A)
Packing	1 pcs / carton case
Net weight	12.6 kg
Use environment	-5℃-40℃
Accessories	1x Controller ,4x Rubber Feet ,1x Air Filter

HC1500D air flow rate curve

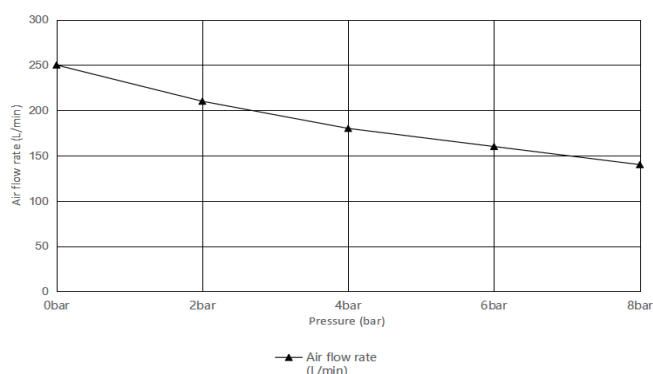

Feature:	Application:
Oil free operation (maintenance free)	Manual DIY
Brushless Motor with longer life	Oxygen concentrator
Lower vibration & noise	Electric vehicles
Imported consumable parts	Solar Pond Aerator
Lighter weight & smaller volume than AC	Field mast
24 hour continuous & stable output	Biology system

DC Oil Free Air Compressor



HC550D-24L

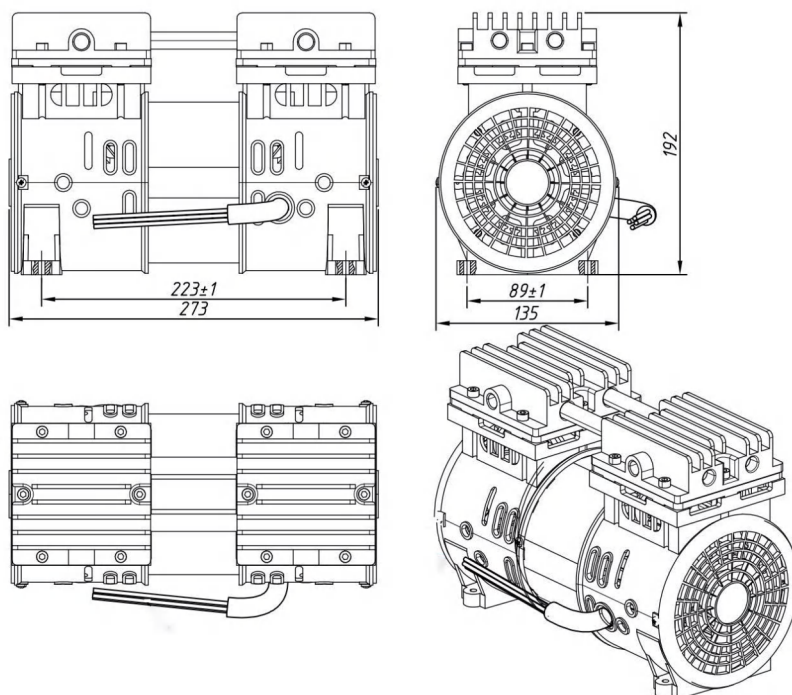

Technical Specification

Model	HC550D-24L
Air flow rate	100 L/min@0 bar
	75 L/min@2 bar
	60 L/min@4 bar
	46 L/min@6 bar
	36 L/min@8 bar
Dimension	520*230*580 mm
Voltage	DC12V /24V /48V
Power	≤550W
Rated speed	1450rpm
Noise	≤67dB(A)
Packing	1 pcs / carton case
Net weight	9.95 kg
Use environment	-5℃ -40℃
Accessories	1x Controller ,4x Rubber Feet ,1x Air Filter

HC550D air flow rate curve

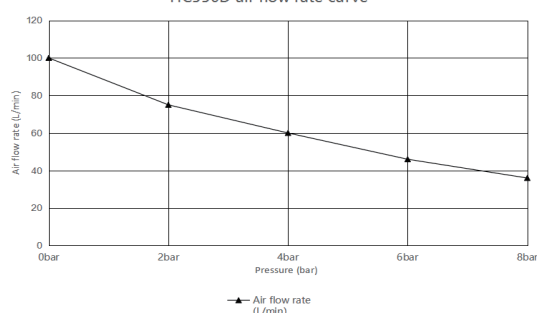

Feature:	Application:
Brushless Motor	Manual DIY
Super Quiet	Oxygen concentrator
Long service life	Electric vehicles
High Quality Material	Solar Pond Aerator
Lighter weight & smaller volume than AC	Field mast
24 hour continuous & stable output	Biology system

Accessories

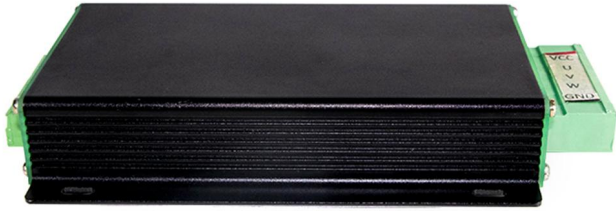

Controller



Cylinder



Silencer



Food pad



Piston Ring



Fan and cover

HCEM·鸿川医疗科技

HONGCHUAN MEDICAL TECHNOLOGY CO.,LTD



Web



Alibaba Web



1688 Web

Tell: 0579-85395979 Fax: 0579-85395960

Address : 1559 Guangshun Street, Xiaoshun Town, Jindong District, Jinhua City, Zhejiang Province , 321035