

AC Air Compressor

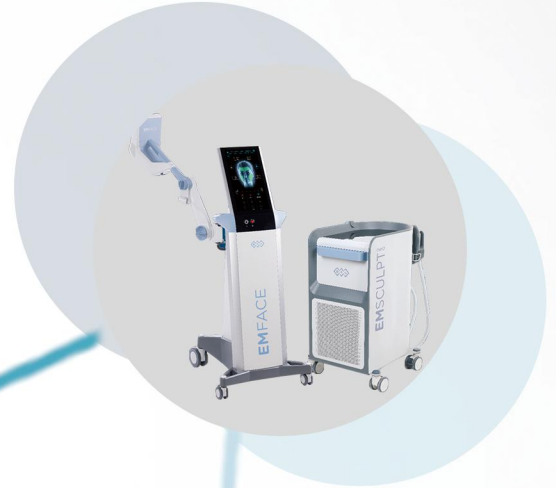

浙江鸿川医疗科技有限公司

Zhejiang Hongchuan Medical Technology Co.,Ltd



Company Introduction:

Zhejiang Hongchuan Medical Technology Co.,Ltd was first established in 2010 , which is a large-scale enterprise group ,we are specializing in R&D and manufacturing various kinds of air compressor , vacuum pump and automatic disinfection machine .

Our products mainly serve industries such as medical equipment, dental equipment ,robotic arms, automation equipment, beauty equipment, packaging equipment, new energy vehicles and pond aeration systems etc .

Dedicated to strict quality control and thoughtful customer service, our experienced engineers are always available to discuss your requirements and ensure full customer satisfaction. From the structural design , appearance design and mold development are all done by our own R&D team .

For all products ,we all have 2-5 years quality warranty .We have a very rigid inspection process , and all goods need 3 times QC inspection, so we can make sure good quality.

Our company don't have complicated application process, so if you have any requirement, we can react much faster without waiting for application result for a long time.

Our products are sold well in all cities and provinces around China, and also exported to USA , Germany ,UK , Italy ,Spain ,New Zealand, Australia , Russia , Indonesia and South Korea etc.

We are welcome the OEM and ODM orders. Whether selecting a current product from our catalog or seeking engineering assistance for your application, you can talk to our customer service center about your sourcing requirements.

Adhering to the business principle of mutual benefits, we have had a reliable reputation among our customers because of our professional services, quality products and competitive prices.

If you have questions or thoughts , please contact us freely. Most of our customers have 30-50% increase of business every year, we hope we can also help your business grow, and let's grow together.

Authorization

Certificates



Utility Patents



Application



Dental Equipment



Laboratory And Medical



Ozone Generator



Beauty Machine



Oxygen Machine



Pond Aerator

AC Oil Free Air Compressor



HC1500A

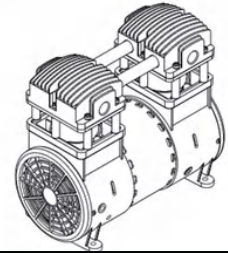
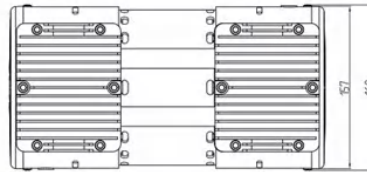
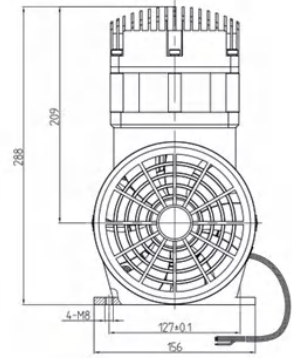
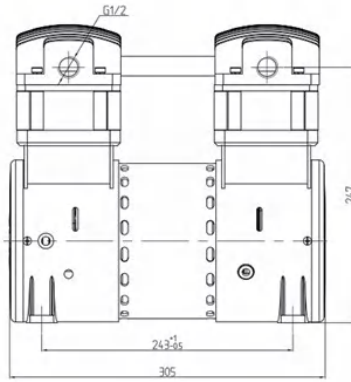

Technical Specification	
Model	HC1500A
Voltage	220V /110V
Power	1500W
Air flow rate	250 L/min@0 bar 200 L/min@2 bar 180 L/min@4 bar 153 L/min@6 bar 120 L/min@8 bar
Noise	≤72dB(A)
Dimension	305*156*288 mm
Installation size	127*243 mm
Net weight	17.5 kg

HC1500A air flow rate curve

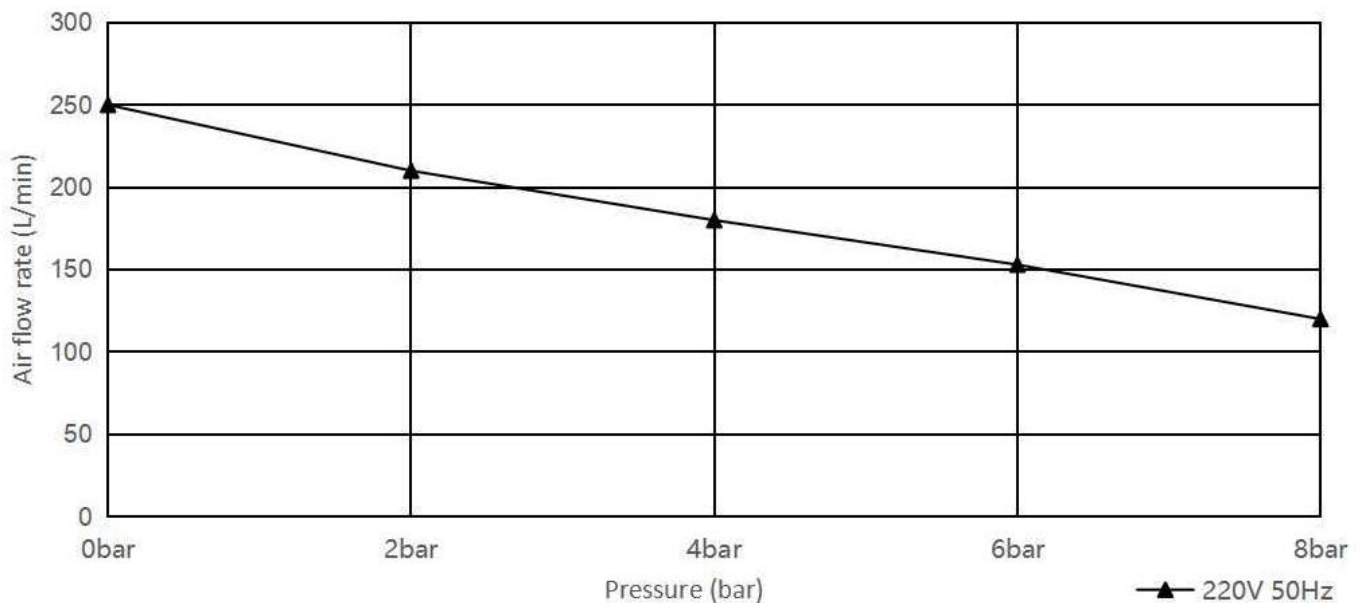

AC Oil Free Air Compressor



HC1100A

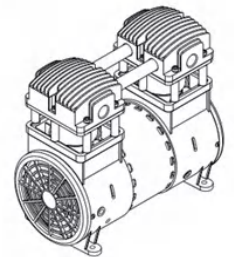
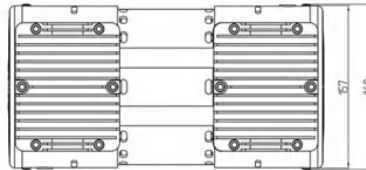
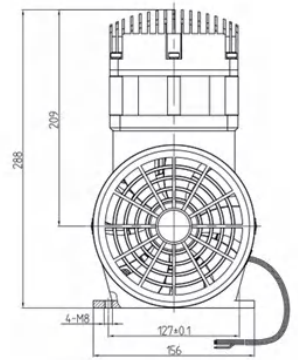
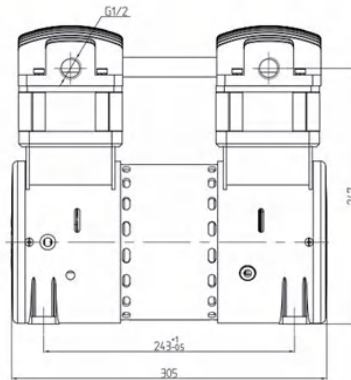

Technical Specification

Model	HC1100A
Voltage	220V / 110V
Power	1100W
Air flow rate	200 L/min@0 bar 160 L/min@2 bar 137 L/min@4 bar 125 L/min@6 bar 100 L/min@8 bar
Noise	≤72dB(A)
Dimension	305*156*288 mm
Installation size	127*243 mm
Net weight	17.0 kg

HC1100A air flow rate curve

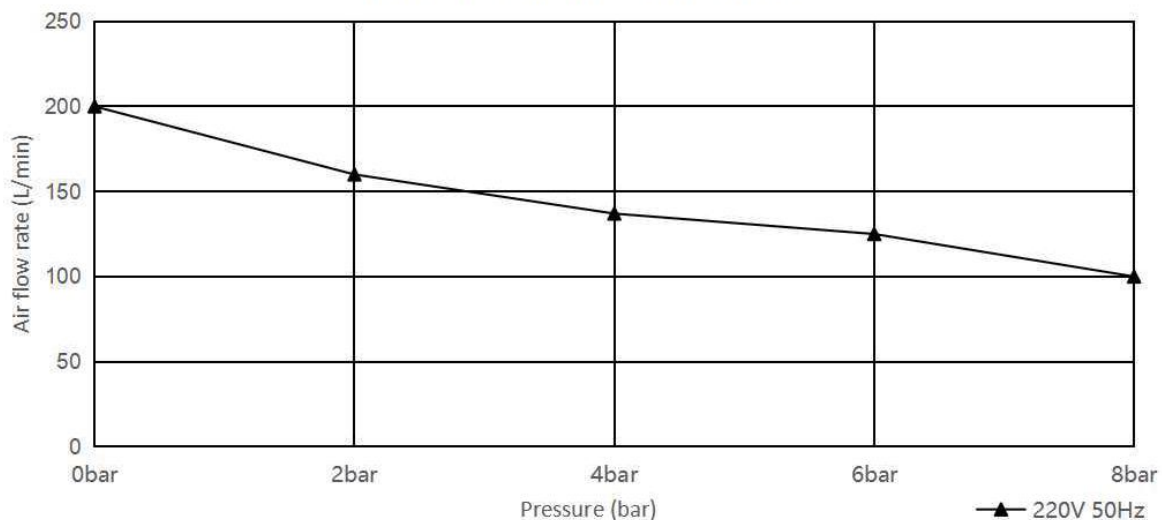

AC Oil Free Air Compressor

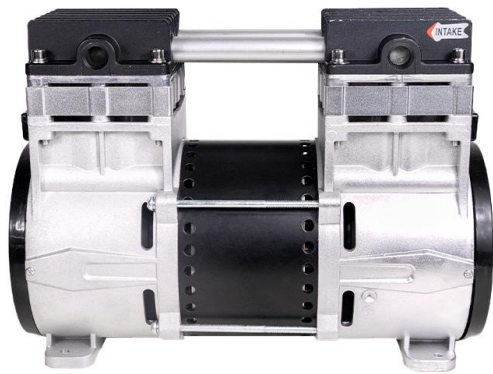

HC750A1

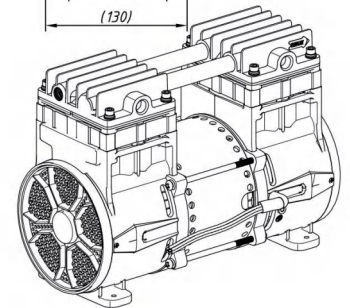
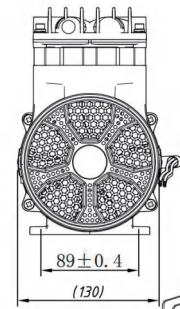
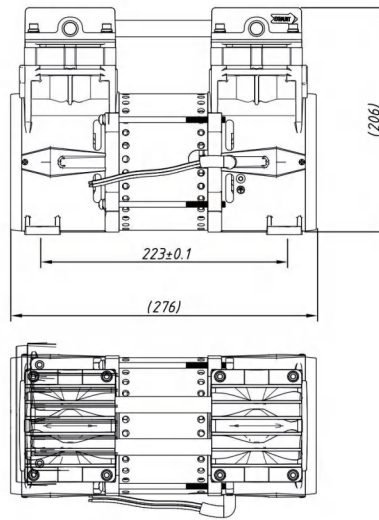

Technical Specification

Model	HC750A1
Voltage	220V /110V
Power	680W
Air flow rate	130 L/min@0 bar 106 L/min@2 bar 88 L/min@4 bar 73 L/min@6 bar 60 L/min@8 bar
Noise	≤68dB(A)
Dimension	276*130*206 mm
Installation size	89*223 mm
Net weight	9.6 kg

HC750A1 air flow rate curve

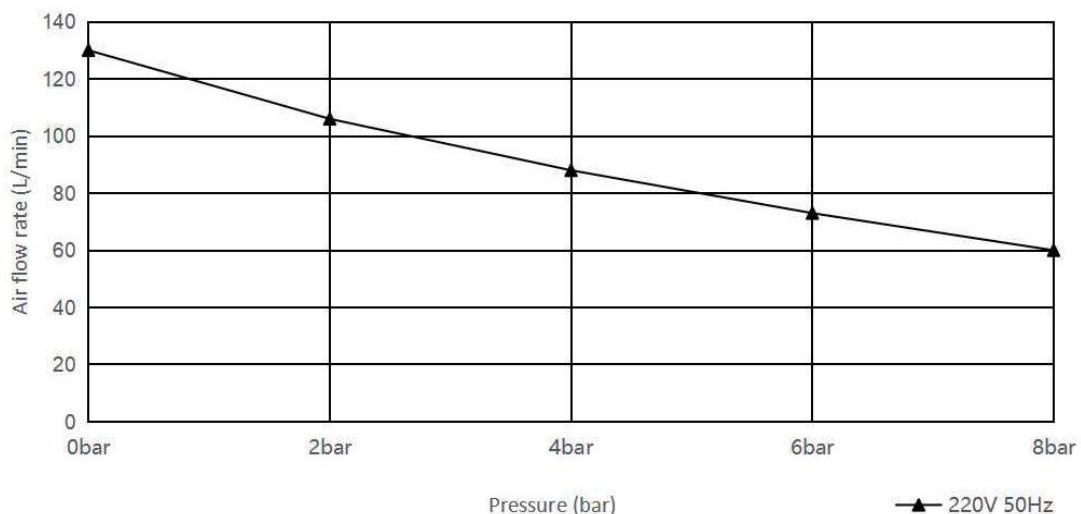

AC Oil Free Air Compressor

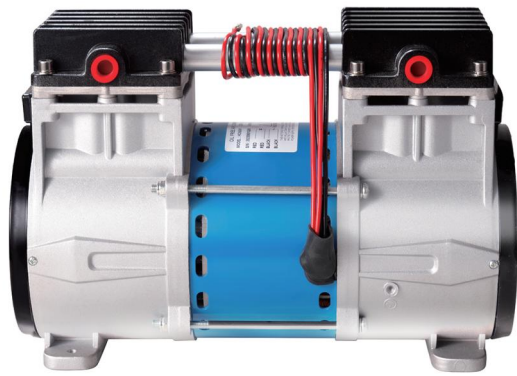

HC550A1

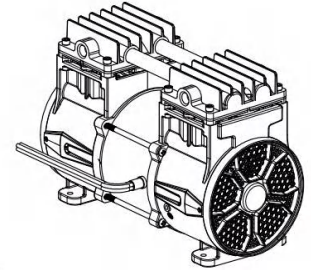
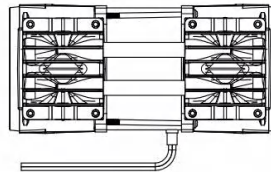
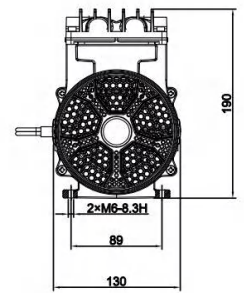
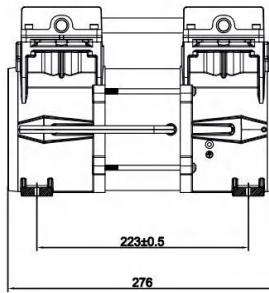

Technical Specification

Model	HC550A1
Voltage	220V /110V
Power	≤470W
Air flow rate	106 L/min@0 bar 86 L/min@2 bar 66 L/min@4 bar 53 L/min@6 bar 40 L/min@8 bar
Noise	≤67dB(A)
Dimension	276*130*190 mm
Installation size	89*223 mm
Net weight	8.86 kg

HC550A1 air flow rate curve

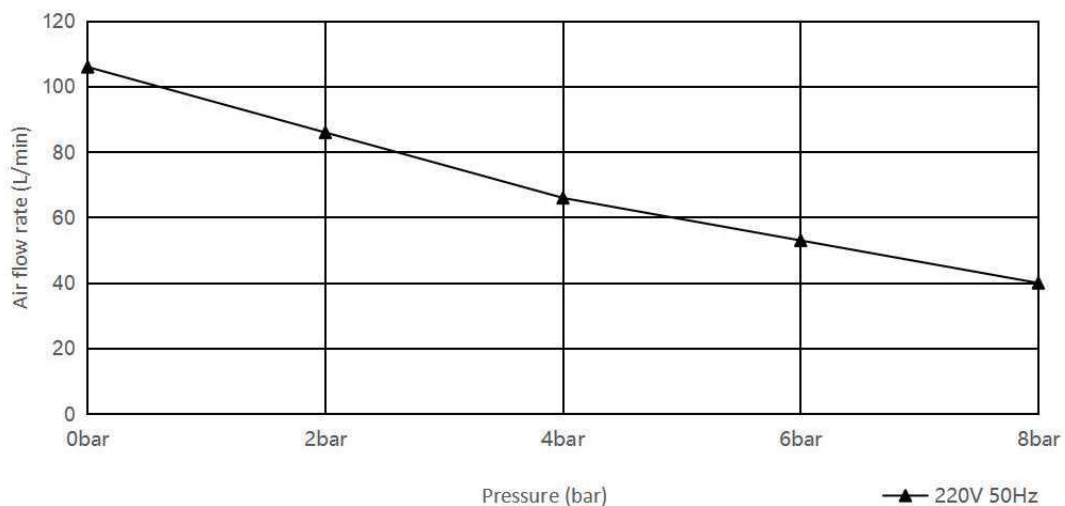

AC Oil Free Air Compressor



HC280A

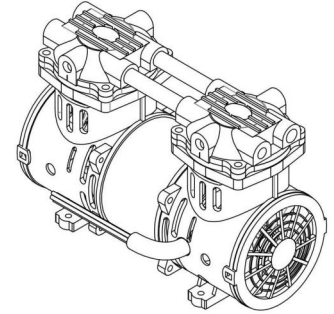
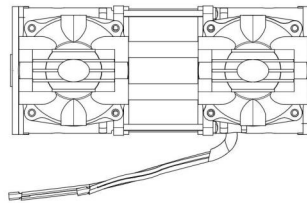
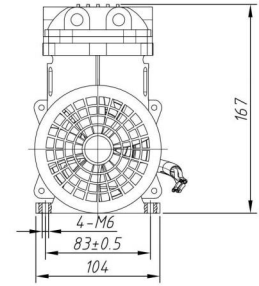
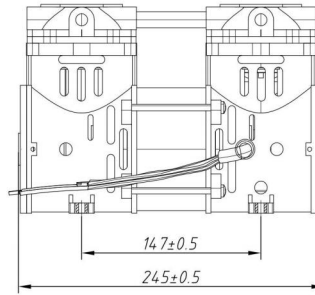

Technical Specification	
Model	HC280A
Voltage	220V /110V
Power	430W
Air flow rate	75 L/min@ 0 bar 50 L/min@ 2 bar 30 L/min@ 4 bar 21 L/min@ 6 bar 15 L/min@ 7 bar
Noise	≤65dB(A)
Dimension	245*104*167 mm
Installation size	83*148 mm
Net weight	6.05 kg

Feature:	Application:
Oil free operation (maintenance free)	Water Treatment
Low vibration & noise	Laboratory
Thermally protected motor	
Imported consumable parts	
24 hour continuous & stable output	

AC Oil Free Air Compressor

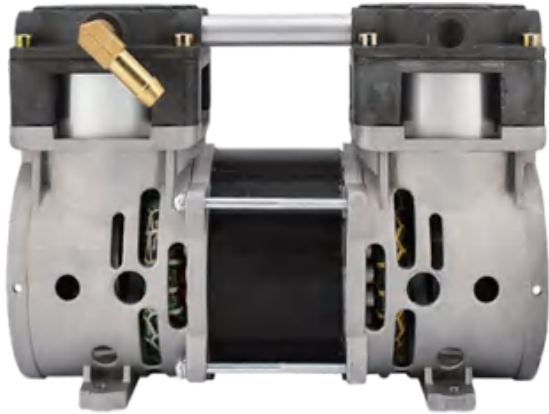

HC280B

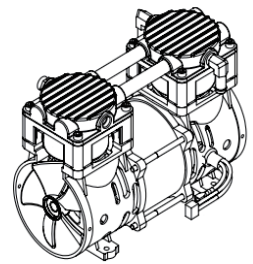
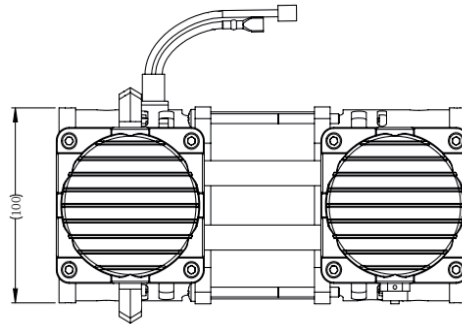
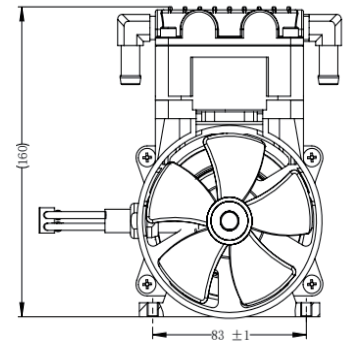
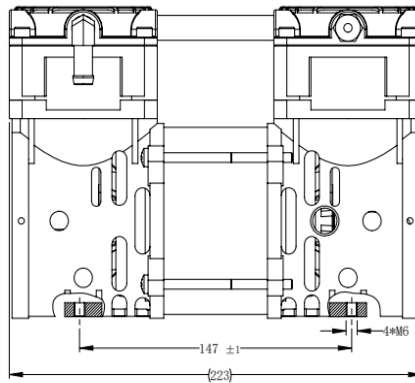

Technical Specification	
Model	HC280B
Voltage	220V /110V
Power	≤370W
Air flow rate	≥ 70 L/min @2bar
Noise	≤59dB(A)
Dimension	223*100*160 mm
Installation size	83*147mm
Net weight	6.0kg

Feature:	Application:
Oil free operation (maintenance free)	Oxygen Concentrator
Low vibration & noise	
Thermally protected motor	
Imported consumable parts	
24 hour continuous & stable output	

AC Oil Free Air Compressor



HC250A

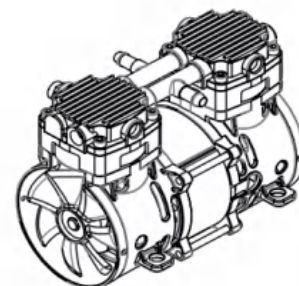
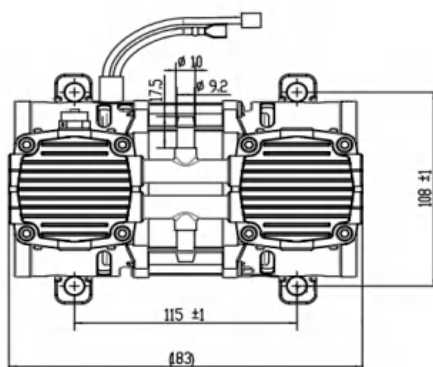
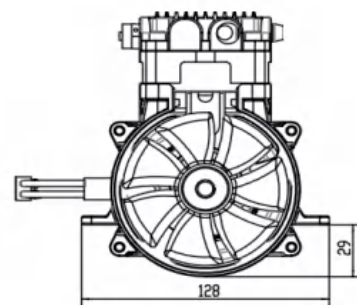
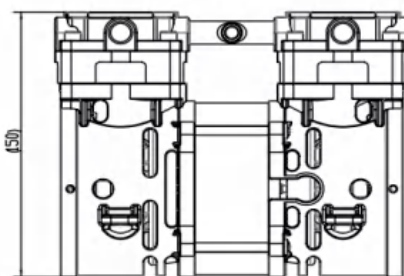

Technical Specification

Model	HC250A
Voltage	220V /110V
Power	≤280W
Air flow rate	≥ 65 L/min @ 1.4 bar
Noise	≤56dB(A)
Dimension	183*98*150 mm
Installation size	115*108 mm (4Xφ10)
Net weight	4.5kg

Feature:	Application:
Oil free operation (maintenance free)	Oxygen Concentrator
Low vibration & noise	
Thermally protected motor	
Imported consumable parts	
24 hour continuous & stable output	

AC Oil Free Air Compressor

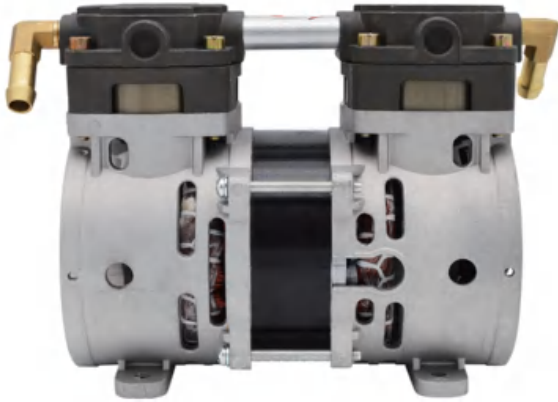

HC210F

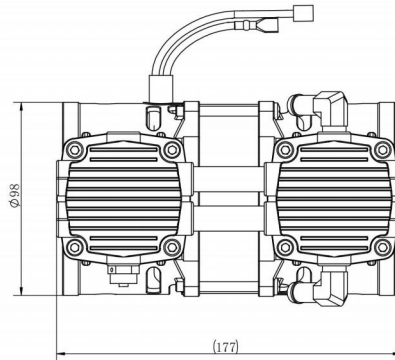
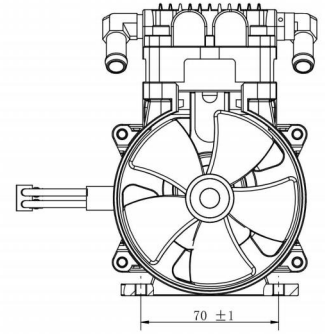
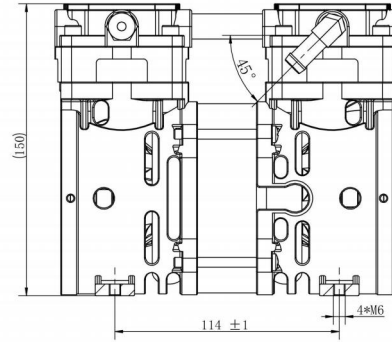

Technical Specification	
Model	HC210F
Voltage	220V /110V
Power	≤240W
Air flow rate	≥ 50 L/min @ 1.4 bar
Noise	≤56dB(A)
Dimension	114*70 mm(4XM6)
Installation size	114*70 mm
Net weight	3.8kg

Feature:	Application:
Oil free operation (maintenance free)	Oxygen Concentrator
Low vibration & noise	
Thermally protected motor	
Imported consumable parts	
24 hour continuous & stable output	

AC Oil Free Air Compressor

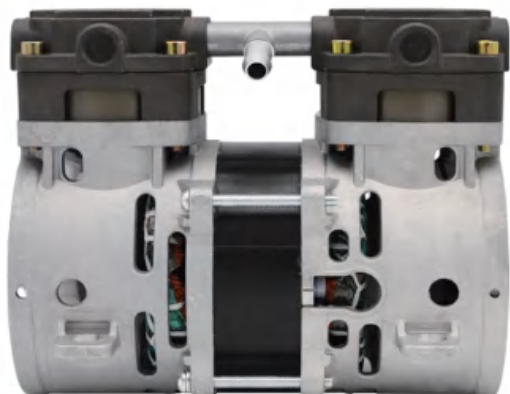

HC210E

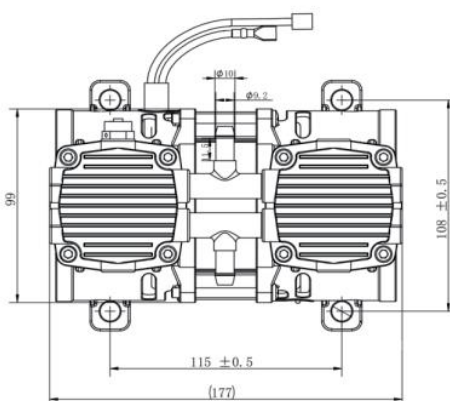
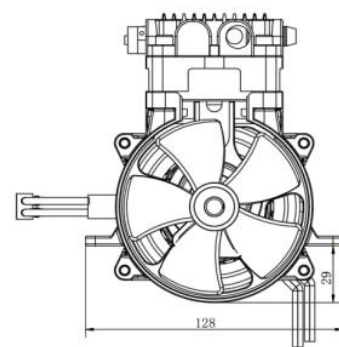
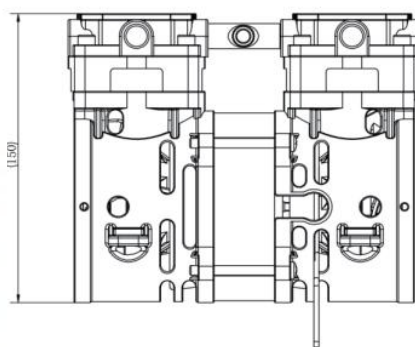

Technical Specification	
Model	HC210E
Voltage	220V / 110V
Power	≤230W
Air flow rate	≧ 50 L/min @ 1.4 bar
Noise	≤55dB(A)
Dimension	177*98*150 mm
Installation size	115*108 mm(4XM6)
Net weight	3.8kg

Feature:	Application:
Oil free operation (maintenance free)	Oxygen Concentrator
Low vibration & noise	
Thermally protected motor	
Imported consumable parts	
24 hour continuous & stable output	

AC Oil Free Air Compressor



HC210A

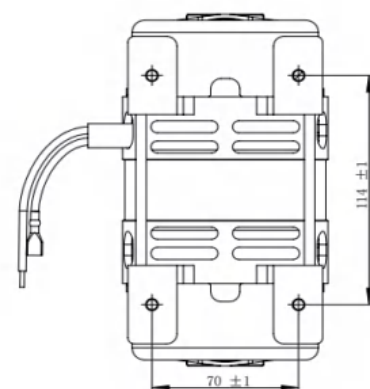
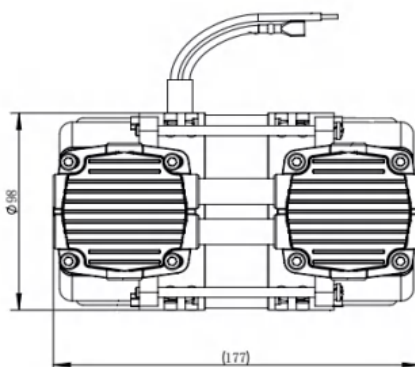
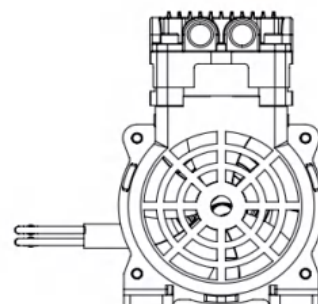
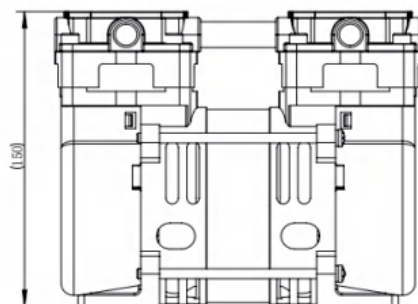

Technical Specification

Model	HC210A
Voltage	220V /110V
Power	≤230W
Air flow rate	≥ 50 L/min @ 1.4 bar
Noise	≤55dB(A)
Dimension	177*98*150 mm
Installation size	70*114 mm(4XM6)
Net weight	3.8kg

Feature:	Application:
Oil free operation (maintenance free)	Oxygen Concentrator
Low vibration & noise	
Thermally protected motor	
Imported consumable parts	
24 hour continuous & stable output	

AC Oil Free Air Compressor



HC100C

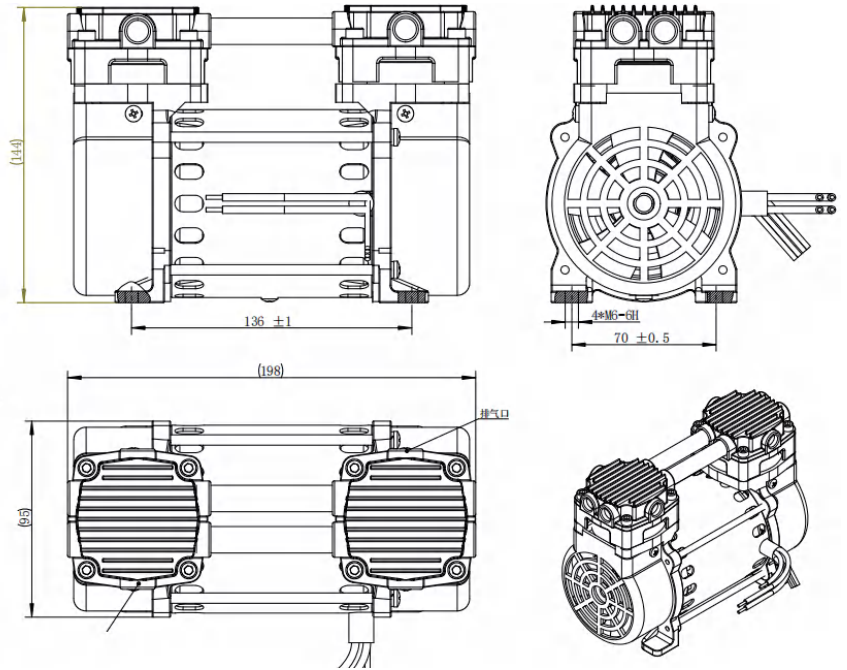

Technical Specification	
Model	HC100C
Voltage	220V / 110V
Power	≤230W
Air flow rate	≥ 9 L/min @ 7 bar ;
Noise	≤55dB(A)
Dimension	198*95*144 mm
Installation size	70*136 mm(4xM6)
Net weight	4.26 kg

Feature:	Application:
Oil free operation (maintenance free)	Water Treatment
Low vibration & noise	Laboratory
Thermally protected motor	
Imported consumable parts	
24 hour continuous & stable output	

AC Oil Free Air Compressor

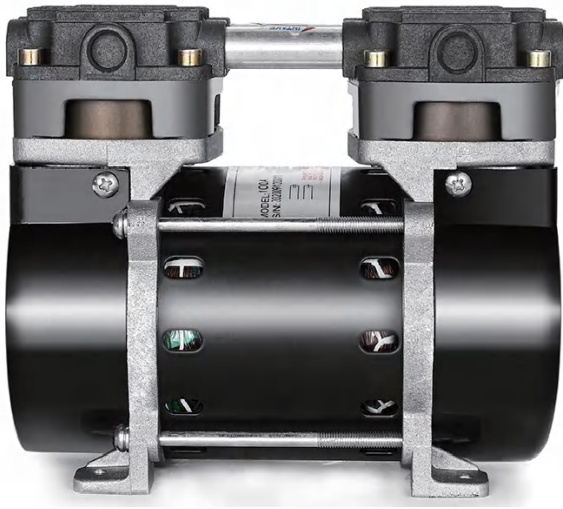

HC100A

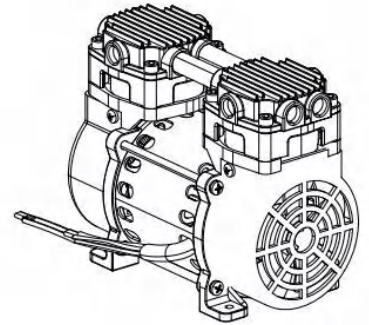
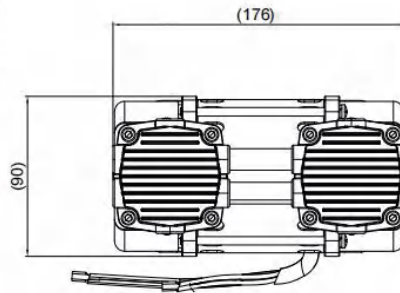
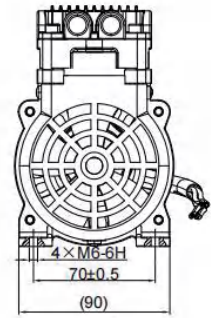
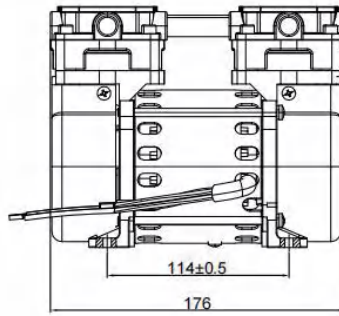

Technical Specification

Model	HC100A
Voltage	220V / 110V
Power	≤160W
Air flow rate	≥ 36 L/min @ 1.4 bar
Noise	≤52dB(A)
Dimension	176*90*143 mm
Installation size	70*114 mm(4XM6)
Net weight	3.8kg

Feature:	Application:
Oil free operation (maintenance free)	Oxygen Concentrator
Low vibration & noise	
Thermally protected motor	
Imported consumable parts	
24 hour continuous & stable output	

AC Oil Free Air Compressor

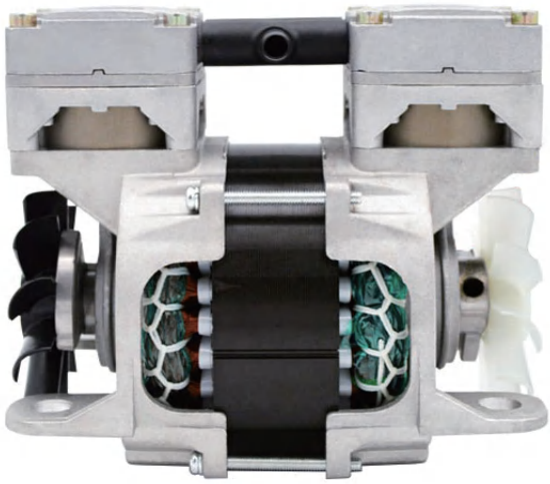

HC80K

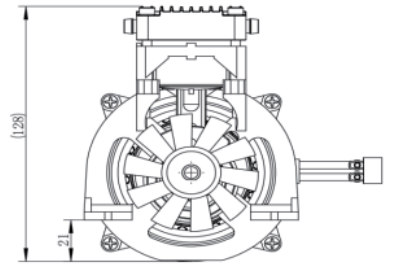
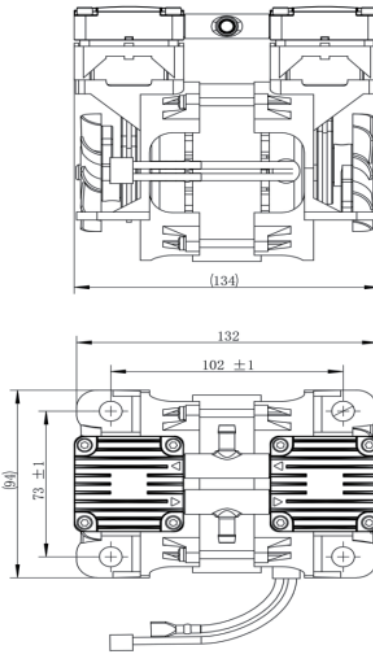

Technical Specification	
Model	HC80K
Voltage	220V /110V
Power	≤125W
Air flow rate	≥ 17 L/min @ 1.4 bar
Noise	≤52dB(A)
Dimension	134*94*128 mm
Installation size	102*73 mm(4Xφ10)
Net weight	2.2 kg

Feature:	Application:
Oil free operation (maintenance free)	Oxygen Concentrator
Low vibration & noise	
Thermally protected motor	
Imported consumable parts	
24 hour continuous & stable output	

AC Oil Free Air Compressor



HC80F

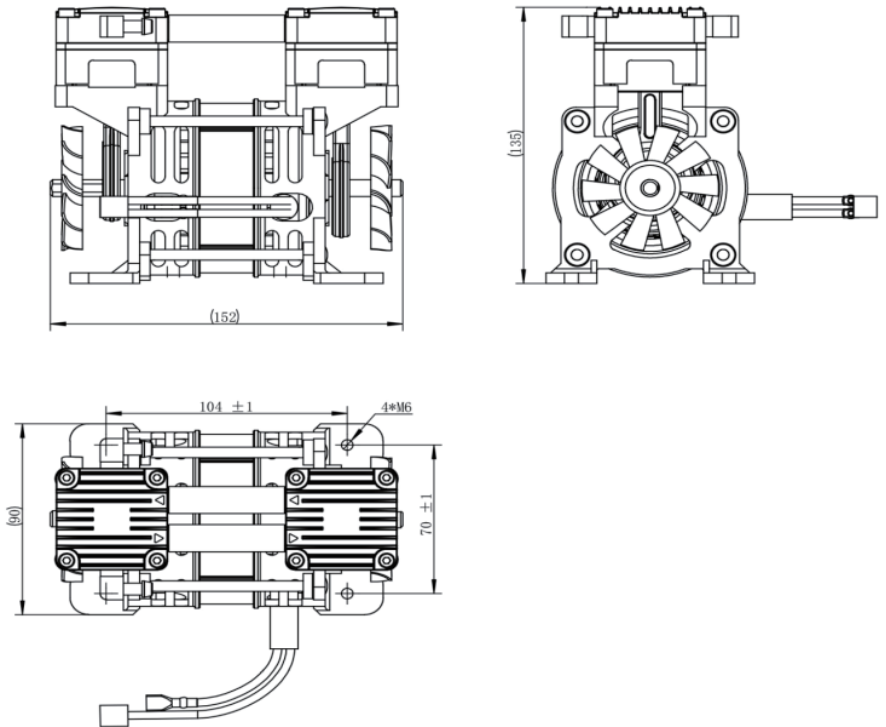

Technical Specification	
Model	HC80F
Voltage	220V / 110V
Power	≤110W
Air flow rate	≥ 17 L/min @ 1.4 bar
Noise	≤52dB(A)
Dimension	152*90*135 mm
Installation size	104*70 mm(4XM6)
Net weight	2.1 kg

Feature:	Application:
Oil free operation (maintenance free)	Oxygen Concentrator
Low vibration & noise	
Thermally protected motor	
Imported consumable parts	
24 hour continuous & stable output	

AC Oil Free Air Compressor



HC80C

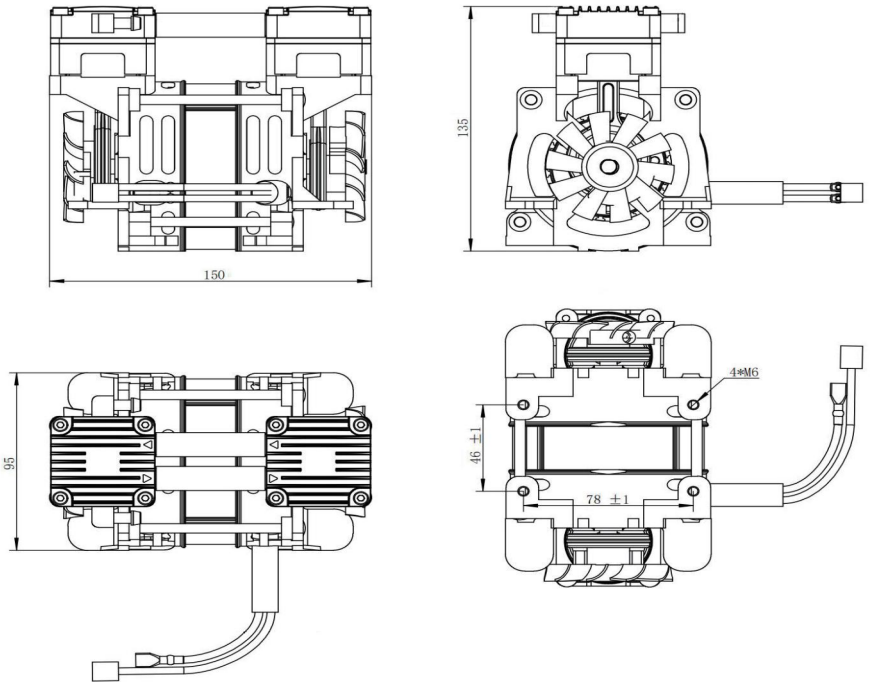

Technical Specification	
Model	HC80C
Voltage	220V /110V
Power	≤110W
Air flow rate	≥ 17 L/min @ 1.4 bar
Noise	≤52dB(A)
Dimension	150*95*135 mm
Installation size	46*78 mm (4XM6)
Net weight	2.59 kg

Feature:	Application:
Oil free operation (maintenance free)	Oxygen Concentrator
Low vibration & noise	
Thermally protected motor	
Imported consumable parts	
24 hour continuous & stable output	

AC Oil Free Air Compressor



HC80A

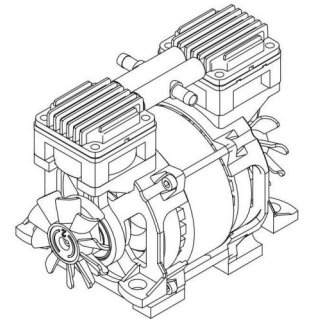
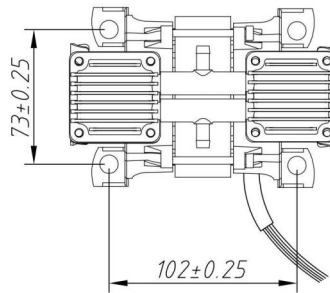
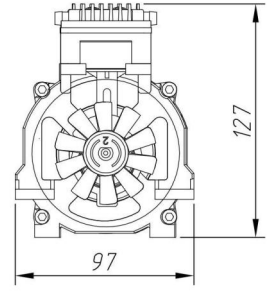
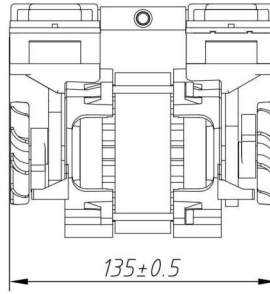

Technical Specification	
Model	HC80A
Voltage	220V /110V
Power	≤110W
Air flow rate	≧ 17 L/min @ 1.4 bar
Noise	≤53dB(A)
Dimension	135*97*127mm
Installation size	102*73 mm(4XM6)
Net weight	2.25 kg

Feature:	Application:
Oil free operation (maintenance free)	Oxygen Concentrator
Low vibration & noise	
Thermally protected motor	
Imported consumable parts	
24 hour continuous & stable output	

NO	PART NO.	N.O. DESCRIPTION	Q.TY
1	350109	SIDE COVER	2
2	250106	LEFT FAN	2
3	350201	ECC.&BEARING ASS'Y	2
4	350110	MOUNT	2
5	350301	CONNECTING ROD ASS'Y	2
6	350301	CONNECT ROD	2
7	350302	PISTON RING	2
8	350303	FASTEN PLATE	2
9	350503	CYLINDER	2
10	350505	CYLINDER SEAL RING	2
11	350400	VALVE PLATE ASSEMBLY	2
12	350404	METAL CUSHION	2
13	350402	INTAKE VALVE	2
14	350401	VALVE PLATE	2
15	350402	EXHAUST VALVE	2
16	350407	FASTEN PART	2
17	350505	O-RING GASKET-HEAD	2
18	350501	CYLINDER COVER	2
19	350507	O" SEAL RING	8
20	350504	CONNECT PIPE	4
21	350506	AIR COOL	1
22	350103	REDUCE VIBRATION PILLARS	4

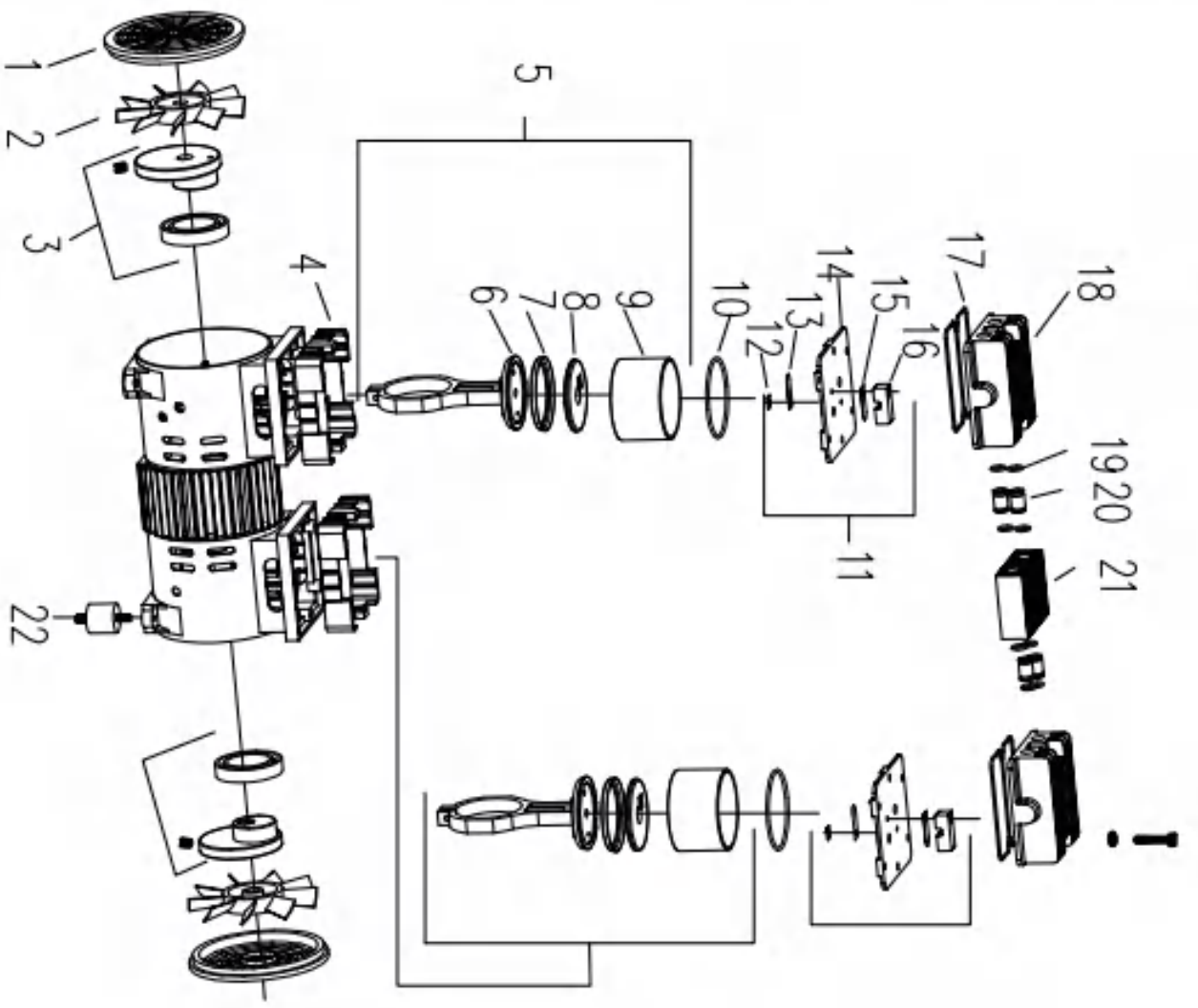

Heavy Duty V Type AC Air Compressor



HC860A

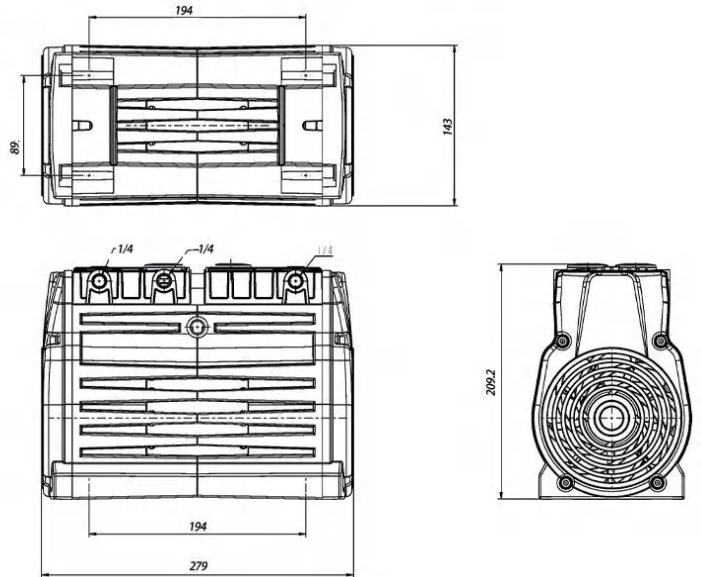

Technical Specification	
Model	HC860A
Voltage	220V /380V
Power	≤1.5kw
Air flow rate	130 L/min @ 0 bar 92 L/min @ 2 bar 77 L/min @ 4 bar 64 L/min @ 6bar 50 L/min @ 8 bar 38 L/min @10 bar
Noise	≤60dB(A)
Dimension	330 x 152 x 220 mm
Installation size	148*323.67 mm
Net weight	13.5 kg

HC860A air flow rate curve

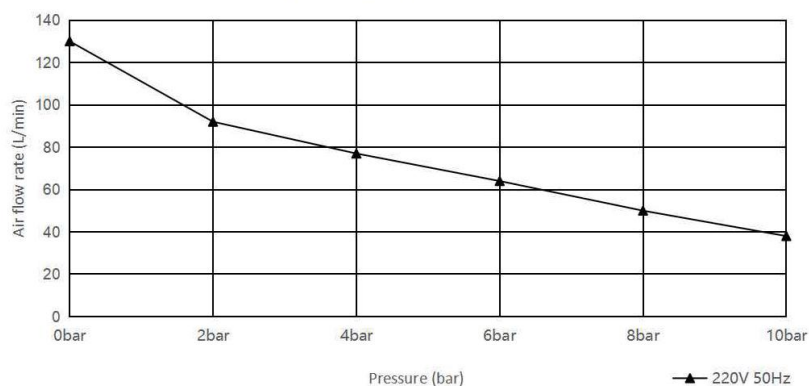

Heavy Duty V Type AC Air Compressor

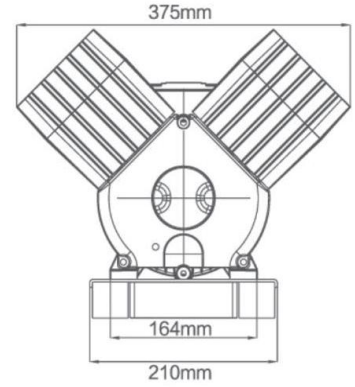
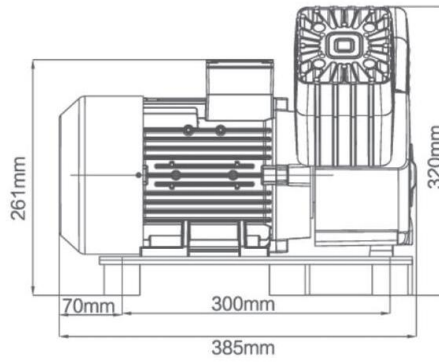

HC502V

Technical Specification

Model	HC 502V
Voltage	220V /380V
Power	≤1.5kw
Air flow rate	200 L/min @ 0 bar 166 L/min @ 2 bar 150 L/min @ 4 bar 133 L/min @ 6 bar 116 L/min @ 8 bar 110 L/min @ 10 bar
Noise	≤70dB(A)
Dimension	385 x 375 x 320 mm
Installation size	164*300 mm
Net weight	34 kg

HC502V air flow rate curve

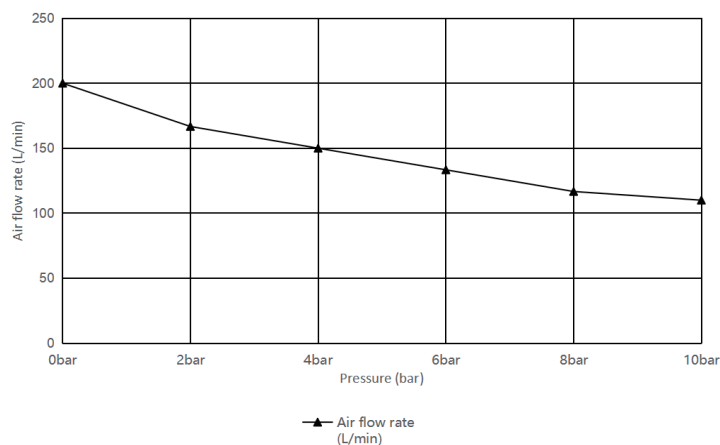

Heavy Duty V Type AC Air Compressor



HC504V

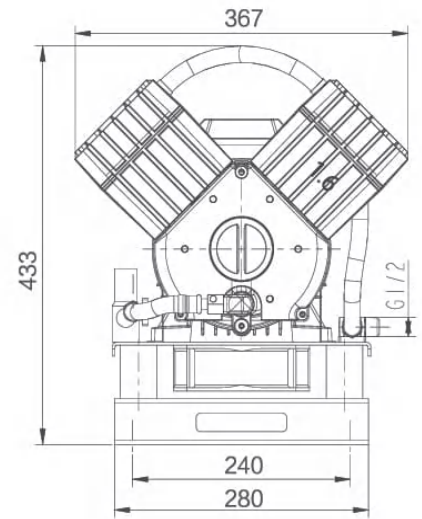
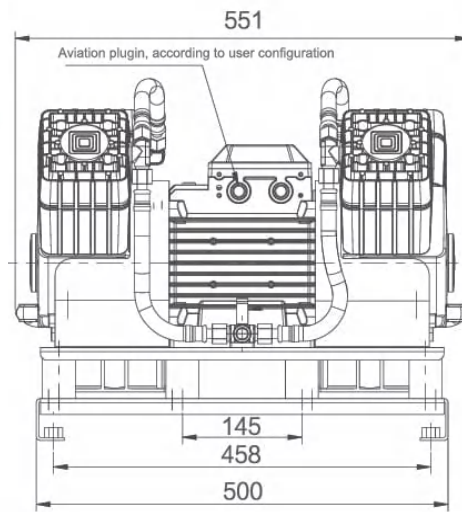

Technical Specification

Model	HC504V
Voltage	220V /380V
Power	≤2.2kw
Air flow rate	400 L/min @ 0 bar 333 L/min @ 2 bar 300 L/min @ 4 bar 266 L/min @ 6 bar 233 L/min @ 8 bar 216 L/min @ 10 bar
Noise	≤70dB(A)
Dimension	551*367*433 mm
Installation size	240*458 mm
Net weight	48 kg

HC504V air flow rate curve

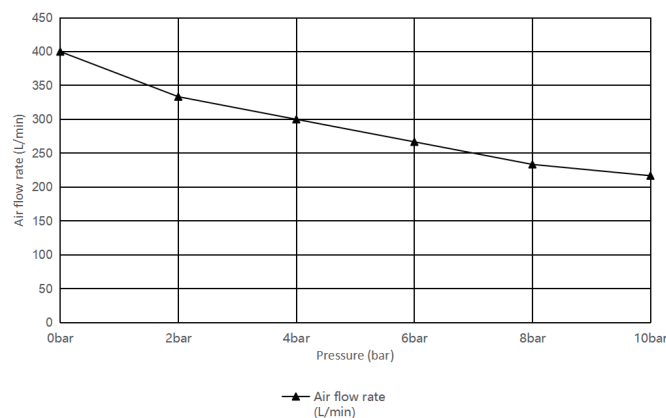

Heavy Duty V Type AC Air Compressor



HC60W3

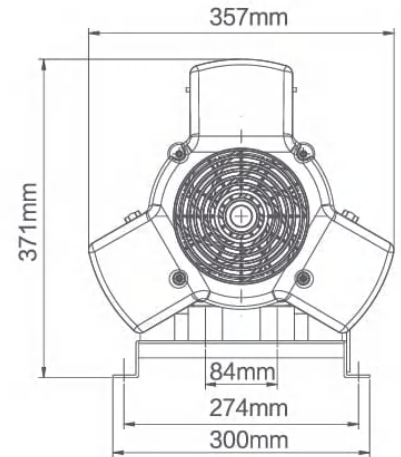
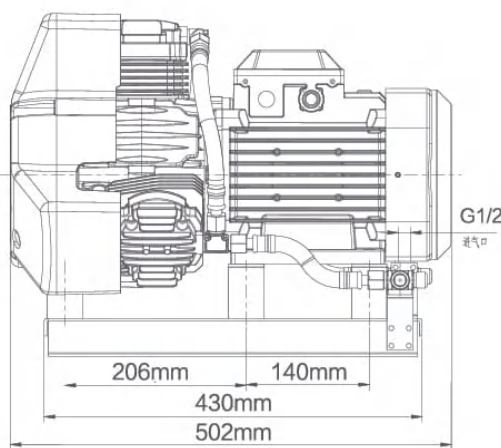

Technical Specification	
Model	HC60W3
Voltage	220V /380V
Power	≤2.2kw
Air flow rate	400 L/min @ 0 bar 316 L/min @ 2 bar 283 L/min @ 4 bar 250 L/min @ 6 bar 233 L/min @ 8 bar 200 L/min @ 10 bar
Noise	≤70dB(A)
Dimension	502 x 357 x 371 mm
Installation size	274*430 mm
Net weight	38 kg

HC60W3 air flow rate curve

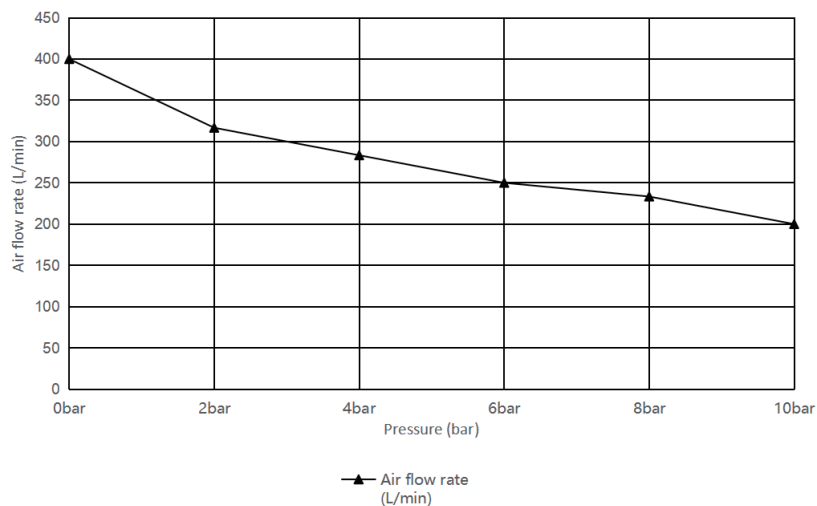

Heavy Duty V Type AC Air Compressor



HC60W6

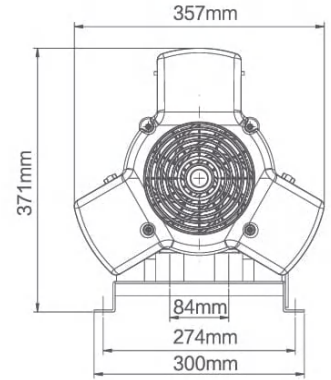
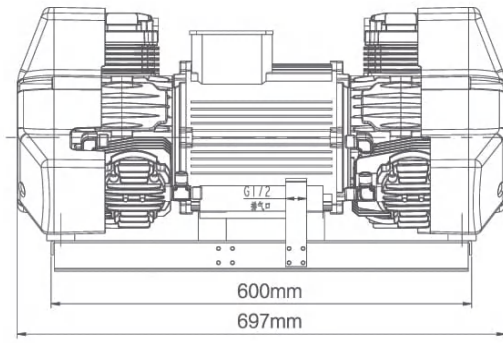

Technical Specification

Model	HC60W6
Voltage	380V
Power	≤4.0kw
Air flow rate	800 L/min @ 0 bar 650 L/min @ 2 bar 583 L/min @ 4 bar 500 L/min @ 6 bar 450 L/min @ 8 bar 416 L/min @ 10 bar
Noise	≤70dB(A)
Dimension	697 x 357 x 371 mm
Installation size	300*697 mm
Net weight	70 kg

HC60W6 air flow rate curve

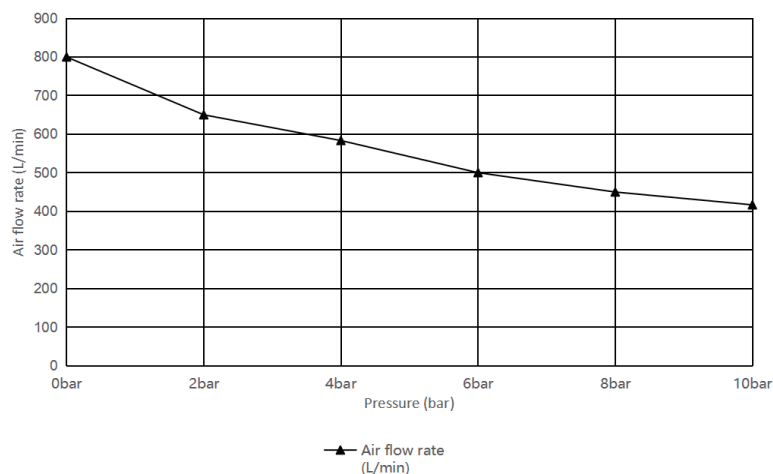

AC Oil Free Complete Machine



HC280AX

Technical Specification

Model	HC280AX
Voltage	220V /110V
Power	≤430W
Air flow rate	40L/min @ 6 bar
Noise	52dB (A)
Net weight	18kg
Dimension	47.5*32*34 cm

Feature:	Application:
Oil free operation (maintenance free)	Dental Equipment
Low vibration & noise	
Thermally protected motor	
Imported consumable parts	
24 hour continuous & stable output	

AC Oil Free Complete Machine



Technical Specification

Technical Specification		
Model	HC5501-30	HC7501-30
Voltage	220V /110V	
Power	470W 0.63 HP	680W 0.9 HP
Air flow rate	40L/min @ 8 bar	60L/min @ 8 bar
Net weight	25kg	28kg
Dimension	43.5*43.5*71 cm	
Tank	30 liter	

Feature:	Application:
Oil free operation (maintenance free)	Dental Equipment
Low vibration & noise	Car Beauty
Thermally protected motor	
Imported consumable parts	
24 hour continuous & stable output	

AC Oil Free Complete Machine



Technical Specification

Technical Specification		
Model	HC5502-50	HC7502-50
Voltage	220V /110V	
Power	2*470W 1.25 HP	2*680W 1.81 HP
Air flow rate	80 L/min @ 8 bar	120 L/min @ 8 bar
Net weight	50kg	54kg
Dimension	75*48*86.5 cm	
Tank	50 liter	

Feature:	Application:
Oil free operation (maintenance free)	Dental Equipment
Low vibration & noise	Car Beauty
Thermally protected motor	
Imported consumable parts	
24 hour continuous & stable output	

AC Oil Free Complete Machine



Technical Specification

Technical Specification		
Model	HC5503-100	HC7503-100
Voltage	220V / 110V	
Power	3*470W 1.88 HP	3*680W 2.72 HP
Air flow rate	120 L/min @ 8 bar	180 L/min @ 8 bar
Net weight	63kg	67kg
Dimension	87.5*48*86.5 cm	
Tank	100 liter	

Feature:	Application:
Oil free operation (maintenance free)	Dental Equipment
Low vibration & noise	Car Beauty
Thermally protected motor	
Imported consumable parts	
24 hour continuous & stable output	

AC Oil Free Complete Machine



Technical Specification

Technical Specification		
Model	HC5504-120	HC7504-120
Voltage	220V /110V	
Power	4*470W 2.5 HP	4*680W 3.63 HP
Air flow rate	160 L/min @ 8 bar	240 L/min @ 8 bar
Net weight	86kg	90kg
Dimension	122x50x 90 cm	
Tank	120 liter	

Feature:	Application:
Oil free operation (maintenance free)	Dental Equipment
Low vibration & noise	Car Beauty
Thermally protected motor	
Imported consumable parts	
24 hour continuous & stable output	

Silent Oil Free Air Compressor With Cabinet



Technical Specification

Technical Specification		
Model	HC1530X	HC1730X
Voltage	220V /110V	
Power	470W 0.63 HP	680W 0.9 HP
Air flow rate	40L/min @ 8 bar	60L/min @ 8 bar
Noise	≤56dB(A)	
Net weight	62kg	65kg
Dimension	55*55*85 cm	
Tank	30 liter	

Feature:	Application:
Oil free operation (maintenance free)	Dental Equipment
Low vibration & noise	
Thermally protected motor	
Imported consumable parts	
24 hour continuous & stable output	

Silent Oil Free Air Compressor With Cabinet



Technical Specification		
Model	HC 1100-50X	HC 1500-50X
Voltage	220V /110V	
Power	1100W 1.46 HP	1500W 2 HP
Air flow rate	100L/min @ 8 bar	120 L/min @ 8 bar
Noise	≤60dB(A)	
Net weight	91kg	95kg
Dimension	85*57*97 cm	
Tank	50 liter	

Feature:	Application:
Oil free operation (maintenance free)	Dental Equipment
Low vibration & noise	
Thermally protected motor	
Imported consumable parts	
24 hour continuous & stable output	

NO	PART NO	DESCRIPTION	QTY
23	350703	PRESSURE SWITCH	1
24	350704	CORD	1
25	350711	SAFETY VALVE	1
26	350817	40 PRESSURE GAUAE	1
27	350712	WATER SAPARATOR	1
28	350713	AIRR VALVE	1
29	350818	50 PRESSURE GAUAE	1
30	350714	FITTING	1
31	350715	TWO WAYS CONNESTOR	1
32	350815	NONRETURN VALVE	1
33	350814	EXHAUST TUBE	1
34	350813	ELBOW	1
35	350902	TANK ASSEMBLY	1
36	350901	BUMPER	3
37	350911	DRAIN COCK ASSEMBLY	1

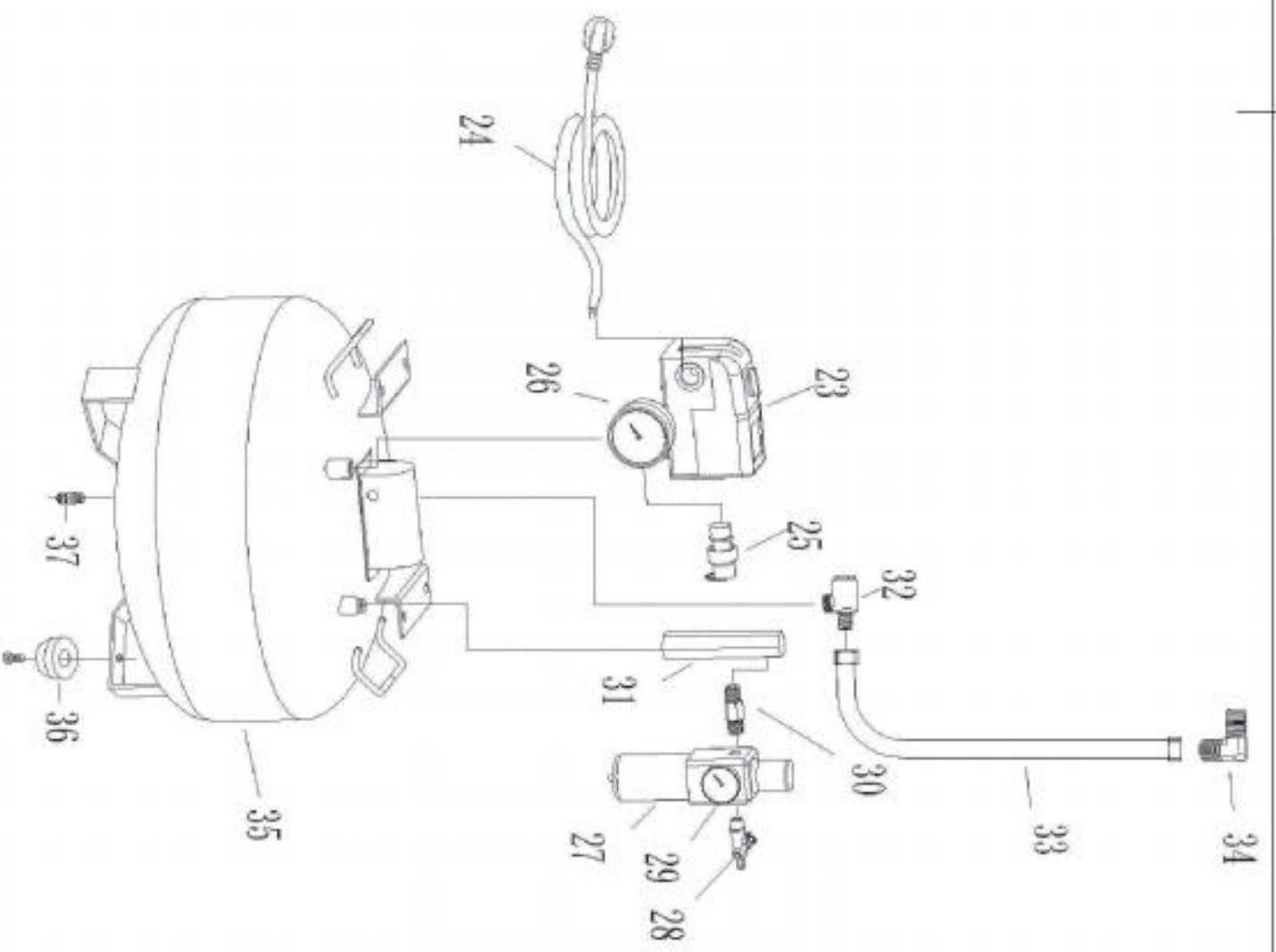

Accessories



Capacitor



Elbow



Silencer



Piston ring



Rubber feet

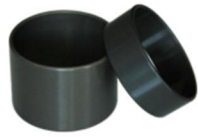

Cylinder



Safety valve



Check valve



Ball valve



Plug



Caster



Pressure switch



Solenoid valve



Oil-water separator



Caster screws



Quick connector



Metal hose



Pressure gauge



Drain valve



Line damping feet



Capacitor cap



Overload protector motor

HCEM·鸿川医疗科技

HONGCHUAN MEDICAL TECHNOLOGY CO.,LTD



Web



Alibaba Web



1688 Web

Tell: 0579-85395979 Fax: 0579-85395960

**Address : 1559 Guangshun Street,Xiaoshun Town, Jindong
District,Jinhua City, Zhejiang Province , 321035**